

# ENTTEC

PROFESSIONAL LED LIGHTING + CONTROL SOLUTIONS  
c a t a l o g u e 2 0 2 2



**ENTTEC HQ / ASIA-PACIFIC**

43 Indian Drive  
Keysborough, VIC 3173  
Australia  
+61 3 9763 5755  
sales@enttec.com.au  
enttec.com.au/support

**ENTTEC AMERICAS**

3874 South Alston Ave, Suite 103  
Durham, NC 27713, USA  
(888) 454-5922  
sales.americas@enttec.com  
enttec.com/support

**ENTTEC EUROPE**

(By appointment only)  
Floor 6, International House  
4 Maddox Street  
London W1S 1QP  
United Kingdom  
+44 (0) 207 061 6210  
sales@enttec.co.uk  
enttec.co.uk/support

facebook.com/enttec



instagram.com/enttecofficial



youtube.com/enttecdotcom



# What's new?

PAGE  
24

For hassle-free automated and interactive shows.



For professional LED pixel light installations.

PAGE  
8

For those who want the ultimate LED dimmer.

PAGE  
21



## Contents

An introduction to ENTTEC	4
The ENTTEC pixel system	6
Lights	8
Controls	16
Show Recorders	24
Software	26
Network	33
DMX Management	34



# Our story.

**GLOBAL HQ  
(ASIA-PACIFIC)**  
MELBOURNE, AUSTRALIA

Australians are well-known for their no-nonsense, pioneering spirit. And having confronted the question, "Why can't I control DMX lights from a computer?" this is precisely what Nicolas Moreau channelled in 1999 when he conceived and developed a world first PC-to-light fixture interface: the **Open DMX USB**.

Designed to be high-quality, affordable, and compatible with existing systems, it was a well-engineered yet deceptively simple device. What's more, as the 'Open' part of the name suggests, its schematics were made

freely available for anybody to study and replicate, thus ensuring that this new technology would rapidly spread and herald previously unheard-of creative possibilities that would revolutionise the lighting industry.

The ENTTEC brand grew from both this product and its transparent philosophy, rapidly developing a reputation, not just for engineering expertise, fine craftsmanship and technical innovation (with several products becoming global industry standards), but also for the kind of fast and flexible support and service that lighting professionals demand. We set out to treat our clientele as we'd like to be treated ourselves - with integrity, proficiency and dedication to achieving the best possible outcome.

## ENTTEC

Entertainment Technology

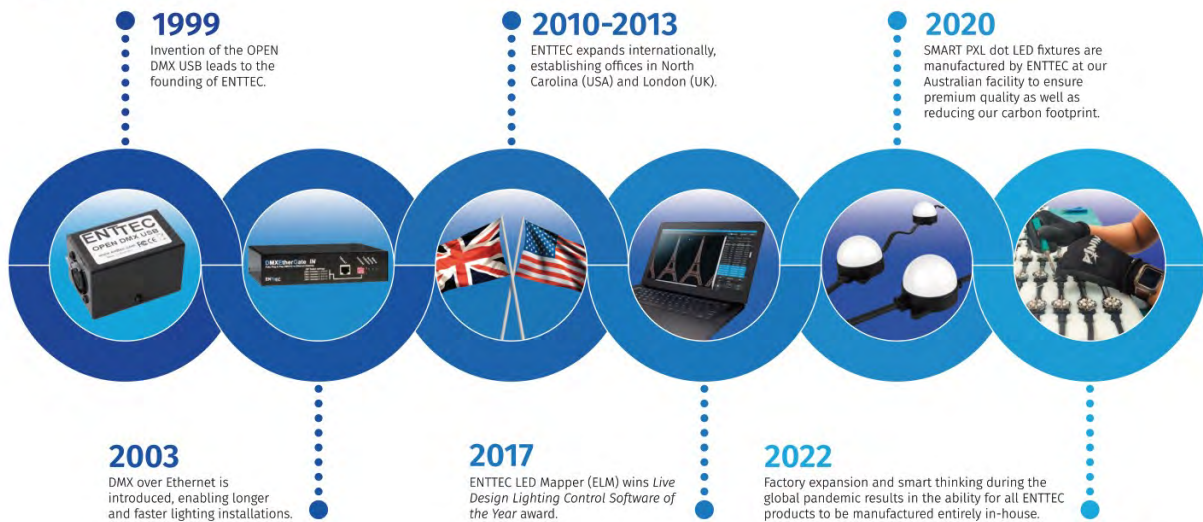

**ENTTEC**

## An introduction to ENTTEC

Dating back to the year 2000, one of ENTTEC's oldest products, the original DMXPlayBack, sits behind its modern day evolution in 2022: the intelligently-designed S-Play SP1-1.



As the scope and popularity of our product range increased, so did the need to expand our operations internationally. To accompany our state-of-the-art design and manufacturing facility in Australia, we established ENTTEC Americas in 2010, based in the famous Research Triangle region of North Carolina, USA, as well as ENTTEC Europe in 2013, with an office in London and dealers throughout the continent.

Now a major player in the global lighting industry - known for our high-end LED luminaires, pixel system innovations, and true end-to-end solutions for virtually any project - we like to keep our focus firmly on the future through continual research and testing.

Our momentum derives from a genuine hunger to push beyond the boundaries of what's currently possible, and the desire to pass our discoveries on to you.

It is our goal to ensure that our products continue to inspire users throughout the world to produce amazing visuals showcasing the zenith of creative technology.

Our products have played a role in projects for a range of international clientele, including:



*"A well-designed and built lighting system does more than provide illumination.*

*It provides inspiration."*

Nicolas Moreau  
ENTTEC founder

# We are the pixel experts.

If you're looking for an end-to-end solution to produce a spectacular lighting display that's not only highly customisable, but simple to configure and control, look no further than ENTTEC's famous pixel system.

Thanks to years of meticulous research and development, our pixel technology is designed to give you the power to harness an incredible selection of compatible devices in a multitude of ways, bringing an almost infinite array of creative possibilities on any scale.

## Why pixels?

With traditional setups, every LED in a series has to do the same as the others. But with pixel technology, each LED can be controlled independently - opening the door to almost countless possibilities.

## The ENTTEC pixel system

### Mapping PAGE 28

To map physical LEDs to video content, you'll need LED mapping software. ENTTEC LED Mapper (ELM) was voted 'Best Lighting Control Software of the Year' by a panel of industry experts at the Live Design Awards 2017.

ELM enables you to map vector curves and other tricky shapes, then use its internal effects library or even your own videos or audio to control your LEDs.

The award-winning ENTTEC LED MAPPER (ELM) software now comes bundled with selected PIXEL PRODUCTS, featuring a FREE license that enables you to map and control the equivalent amount of LED pixels that your chosen product is capable of.

Look out for this icon!



### For larger projects PAGE 19

The PIXELATOR is the world's only Gigabit pixel converter, delivering rock solid LED pixel mapping and perfect synchronisation between its 24 ports. Thanks to its brilliant engineering, it has the power to control up to 8160 pixels (48U).

### For dense pixel arrays PAGE 17

The OCTO is an 8-universe pixel controller with network linking capable of being powered 4-60v DC (the widest voltage range for a controller in its class). With a fast processor and support for protocols with both data and clock, the OCTO is a truly versatile driver.

### Add pixel strips PAGE 10

For tighter spaces and stealth installations, our range of classic 5V and 12V **PIXEL STRIPS** are the way to go. Manufactured to the highest standards, with better substrates and thicker copper than other strips on the market, ENTTEC pixel strips are quality checked and tested by our team of engineers in order to ensure optimal compatibility with our range of controllers.

### Add pixel dots PAGE 8

ENTTEC's **SMART PXL dot** series are the professional choice for LED installations.

These flexible lengths of customizable, high-intensity, full-spectrum LED nodes have been designed from the ground upward for a robust installation. Suited for indoor or outdoor usage, they come in default strings of 20 and feature different diffuser options.

### Inject data + power PAGE 20

Extend your layout up to 300 metres over standard CAT6 cable using ENTTEC's PLink protocol. Developed especially for pixel projects, simply BYO power supply and inject via a **PLINK INJECTOR** (standard and robust IP66 versions available).

Learn more about our **PIXEL PRODUCTS** where you see this icon.



## SMART PXL DOTS

SKU: 73010 / 73011 / 73012 (SMART PXL 40) / 73050 (SMART PXL 60)



Robust and reliable, ENTTEC's 16-bit resolution, individually-addressable SMART PXL dot series are designed to withstand the harshest environments.

With many customisable features, SMART PXL dots can be configured into any conceivable shape. Engineered to create spectacular, crisp lighting effects, they add a stylish design element to any architectural, commercial or entertainment project

### Why SMART PXL dots?

- > Flexible, long-lasting and robust
- > Highly customisable
- > Smooth 16-bit dimming resolution
- > IP67 rating for outdoor use
- > Improved thermal management compared to pixel tape
- > Visual appeal as a conspicuous feature

### Google Pixel Wall

Interactive customer experience for Google's flagship retail stores, designed and installed by Grumpy Sailor using ENTTEC pixel dots.





### SMART PXL 40 DOT (Ø40mm)

#### Lens options + light output



### SMART PXL 60 DOT (Ø60mm)

#### Lens options + light output



### HI-RES.

16-bit native for an ultra-smooth dimming curve and mixing detail that will truly wow your audience – and with an ENTTEC control system, you can also run them in 8-bit mode to double your control channels.



### BRIGHT.

Each SMART PXL node contains premium LEDs, giving an impressive lumen output with different lens options, while thick, tinned copper cabling reduces voltage drop over the length of each string.



### ROBUST.

SMART PXL dot cases are made from a selection of the finest and most durable quality materials available. With a 3-year warranty as standard, these dots are seriously engineered to stand the test of time.



### SECURE.

Offering outstanding protection against moisture and corrosion, SMART PXL internal components are fully-potted (encased in resin) for waterproofing as well as resistance to shock and vibration.



# LED PIXEL STRIPS

SKU: SEE TABLE



Manufactured to the highest standards, our digital pixel strips are designed, quality checked and tested by our team of in-house engineers. Available in different voltages, mapping orders and PCB colours, there's a strip for virtually every situation.

- > Individually-addressable LEDs
- > 32-bit, True Colour display
- > Scan frequency of 400Hz+ /s
- > Custom PCB design to minimise the effects of voltage drop
- > Adhesive backing for quick and easy installation
- > Operating temperature 5°-50°c

We use thicker copper (2-3oz/sqft) and better quality substrates than other strips on the market, meaning:

- > Extra durability
- > Safer (better heat dissipation)
- > Improved current flow
- > Less voltage drop (which means less power re-injection required)

SKU	PRODUCT NAME	MAPPING ORDER	PCB COLOUR	VOLTAGE	LEDs / m
8PXW60-F-12-B	Black pixel strip RGBW (12V) 5m	GRBW	Black	12V	60
8PXW60-4-B	Black pixel strip RGBW 60 (5V) 4m	GRBW	Black	5V	60
8PX60-4	Pixel strip RGBW: 8PX60 (5V) 4m	GRBW	White	5V	60
8PX30-F	Pixel strip RGBW: 8PX30 (5V) 5m	GRBW	White	5V	30
8PX60-12-W	Single pixel LED strip (12V) 5m	GRB	White	12V	60
8PX60-12-B	Black single pixel LED strip (12V) 5m	GRB	Black	12V	60
8PL60-F-12	Pixel tape RGB: 8PL60 (12V) 5m	RGB	White	12V	60
8P60-5-B	Black pixel tape RGB 8P60 (5V) 5m	GRB	Black	5V	60
8PL60-F	Pixel tape RGB: 8PL60 (5V) 5m	GRB	White	5V	60
8PL30-F	Pixel tape RGB: 8PL30 (5V) 5m	GRB	White	5V	30

## 8PX60-12 SERIES: the very latest in LED technology

New advances in design and manufacturing have given us the most sophisticated 12V strip yet, featuring 60 individually-controllable, SINGLE-PIXEL RGB LEDs per metre.

Available with PCB in classic white or stealth black, each LED has its own inbuilt IC, meaning more space has been dedicated to carrying power to further reduce the impact of voltage drop. This, in combination with its 12V input, means lengths of up to 7m can be achieved without the need to re-inject power - a huge benefit for installers.

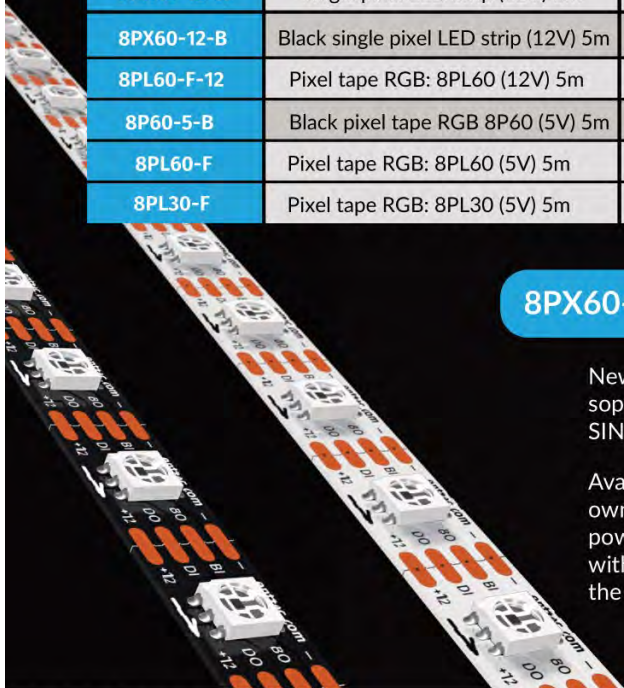

A stunning light sculpture and its beautiful reflection on the tranquil waters of Skovsøen lake in Odense, Denmark ~ Conceived and created by Chaos Engine using 5,400 LED pixels.

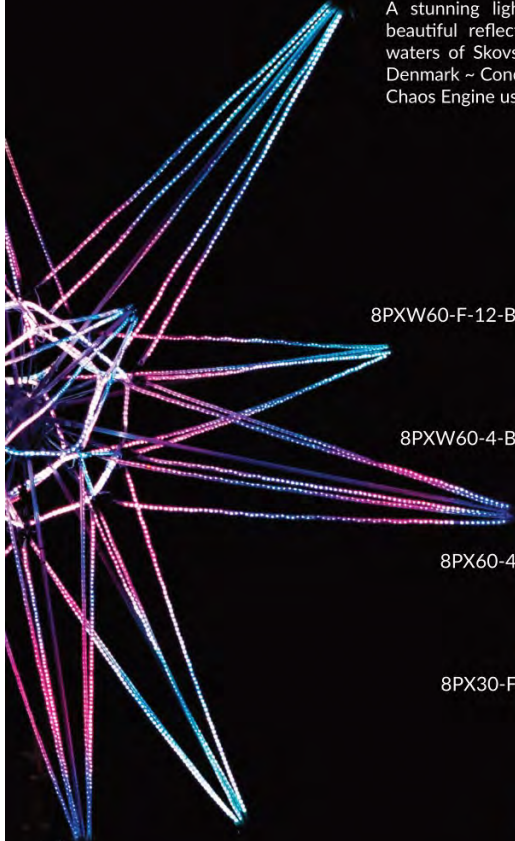

RGBW PIXEL STRIPS

8PXW60-F-12-B



8PXW60-4-B



8PX60-4



8PX30-F



RGB PIXEL STRIPS

8PX60-12-W



8PX60-12-B



8PL60-F-12

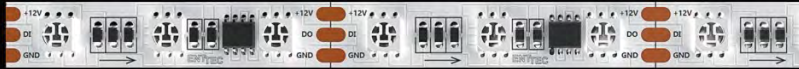

8P60-5-B



8PL60-F



8PL30-F

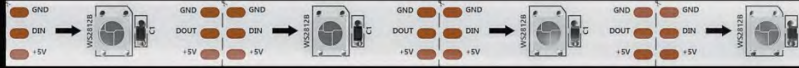

# CONSTANT VOLTAGE (CV) STRIPS

SKU: 9VL4 / 9VLW

Manufactured to suit any desired mood or effect, our CV strips are available in 10m reels of either RGB or RGBW varieties. CV strips are great for uniform designs or injecting some creative flair into any project.

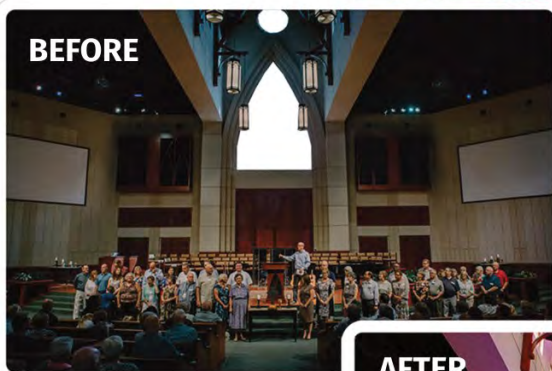

**BEFORE**

- > 24V DC power
- > Easy to control
- > IP20 indoor use only
- > Compatible with the ENTTEC CVC4
- > Engineered and checked by our in-house team

This spectacular transformation of Florida's Seven Rivers Church was undertaken by the team at Summit Integrated.

ENTTEC CV LED tape strips were used to create accents and wall washes that completely change the atmosphere of the space, lifting it to ethereal heights.



**AFTER**

SERIES	PRODUCT CODE	COLOUR	DC POWER	MAX CONTINUOUS LENGTH
9VL	9VL4	RGB	24V	10m
	9VLW	RGBW	24V	10m



RGB STRIP 9VL4



RGBW STRIP 9VLW

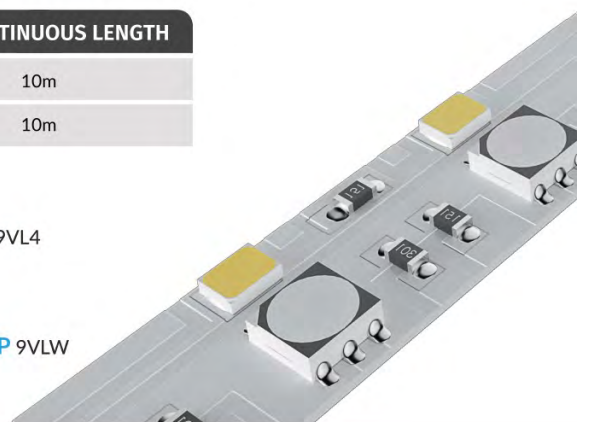

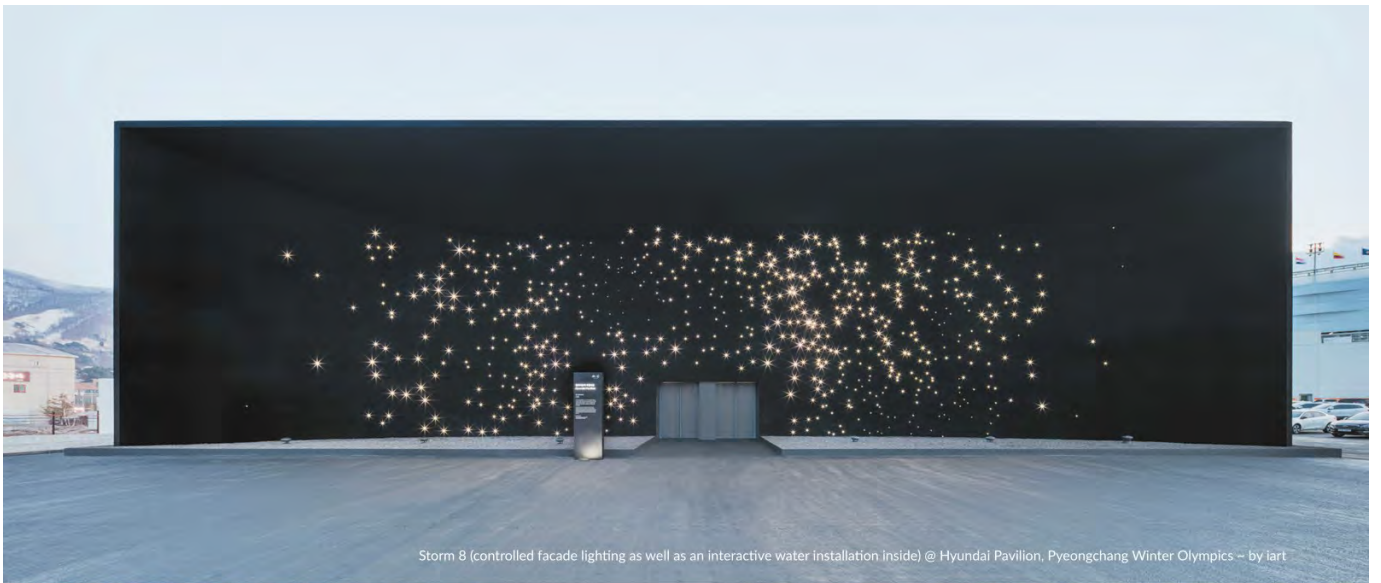

Storm 8 (controlled facade lighting as well as an interactive water installation inside) @ Hyundai Pavilion, Pyeongchang Winter Olympics - by iart



ENTTEC S-Play, Pixelator Mini, PLInk Injectors and 8PL60-F-12 pixel strip @ Ballarat Boom Box DJ booth project, Victoria, Australia - by Illumidy

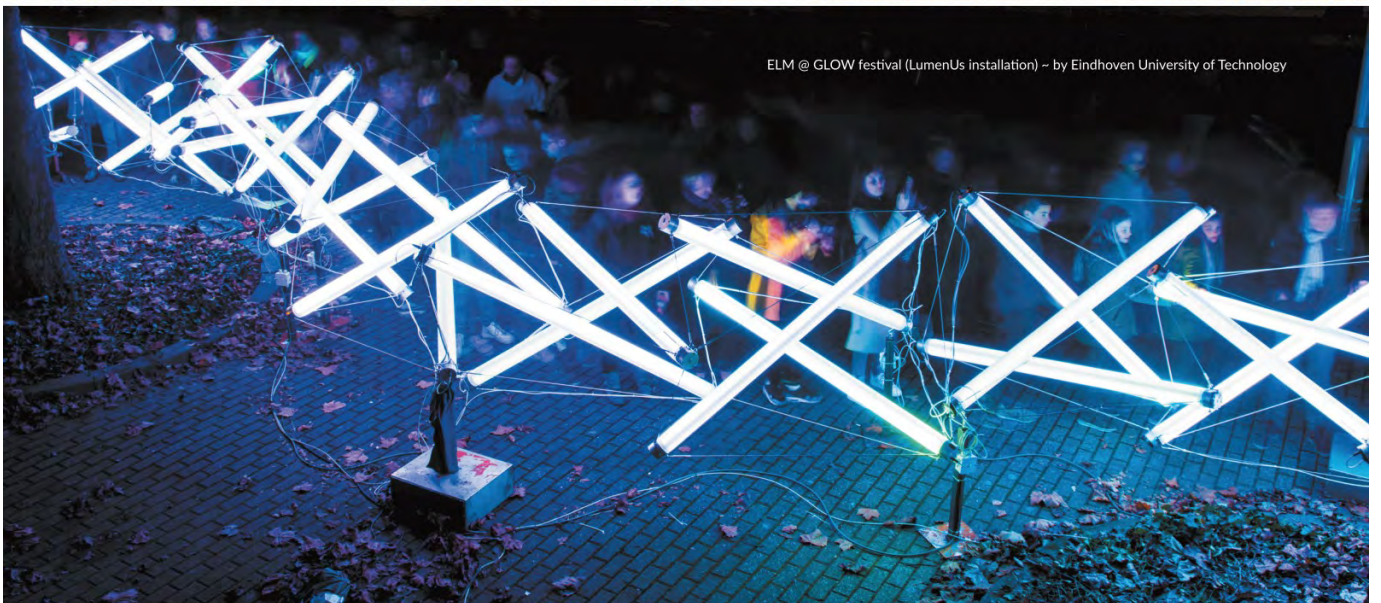

ELM @ GLOW festival (LumenUs installation) - by Eindhoven University of Technology



Interactive multimedia wall featuring LED pixels by ENTTEC aboard Royal Caribbean International's MS Ovation of the Seas  
- by Materials & Methods / Float 4 / Party By Design



ENTTEC constant voltage LED strips @ PLC Performing Arts Centre, Melbourne - by COX Architecture



ENTTEC pixel controllers and 200m of LED pixel strip @ Otherworld, London ~ by Voodoo Vision



## OCTO @ WORK

This is one of the longest suspension footbridges ever constructed and you'll find it spanning a bayside inlet in the coastal city of Ulsan, South Korea.

The LED pixel installation has been mapped using ENTTEC LED Mapper (ELM), controlled by an S-PLAY and fed into a series of OCTOs and DIN Ethergates.

This spectacular light show can be seen at night from the opposite side of the bay.

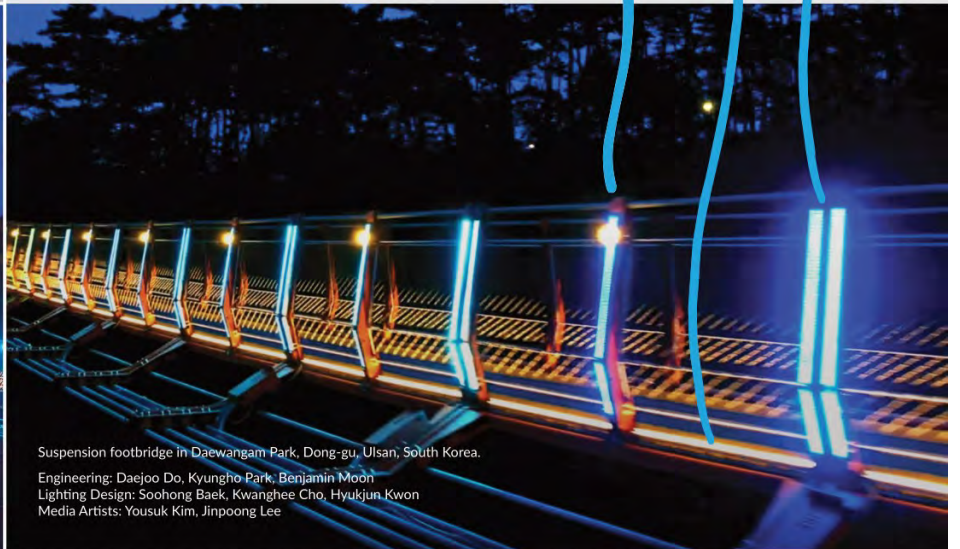
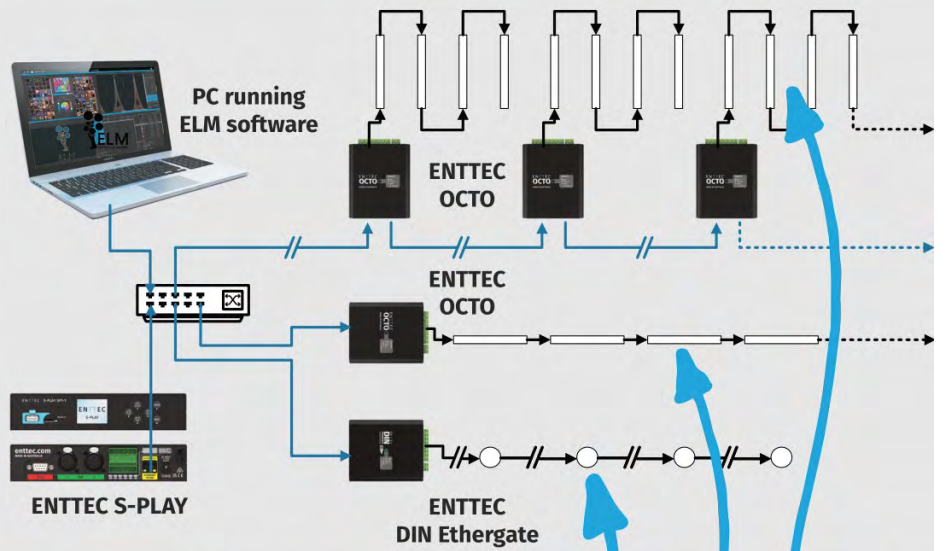

Suspension footbridge in Daewangam Park, Dong-gu, Ulsan, South Korea.  
 Engineering: Daejoo Do, Kyungho Park, Benjamin Moon  
 Lighting Design: Soohong Baek, Kwanghee Cho, Hyukjun Kwon  
 Media Artists: Yousuk Kim, Jinpoong Lee



# OCTO

SKU: 71521



The latest evolution of our 8-Universe, dual-output eDMX to LED pixel data converter, the OCTO is a robust and reliable installation-grade device that connects directly to your pixels, engineered to take any architectural, commercial or entertainment project to the next level.



Designed for ultra-fast deployment of LED strips and pixel dot systems, the OCTO is compatible with a wide range of input and output protocols alongside an industry leading voltage input range.

- > Capable of network chaining
- > Huge list of supported SPI protocols inc. WS, SK, APA and many more
- > Variable voltage input range of 4-60V
- > TS35 DIN rail or surface mount options
- > 'Identify' button + LED for easy testing

DATA/POWER IN



DATA OUT



# DIN PIXIE

SKU: 73539



A smart, cost-effective lighting control solution, the DIN PIXIE is a compact, 2-Universe DMX to LED pixel protocol converter and standalone player, engineered to take any architectural, commercial or entertainment project to the next level.



- > 5-48V DC input range
- > Control up to 340 RGB or 256 RGBW pixels per output
- > Supports a wide range of strips/dots
- > Pre-program or run live
- > 2 x DMX ports (in only, not daisy chain)
- > USB control API for custom applications

DATA/POWER IN



DATA OUT

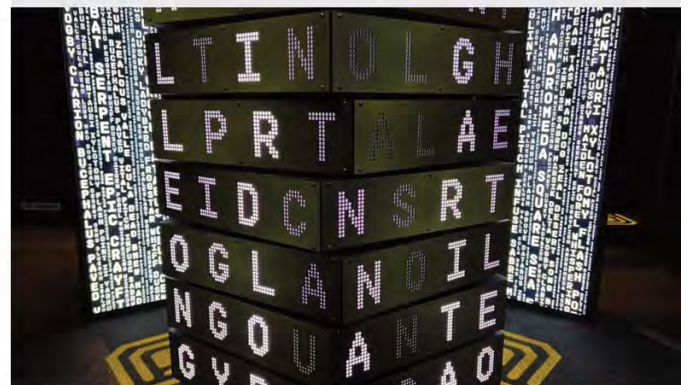
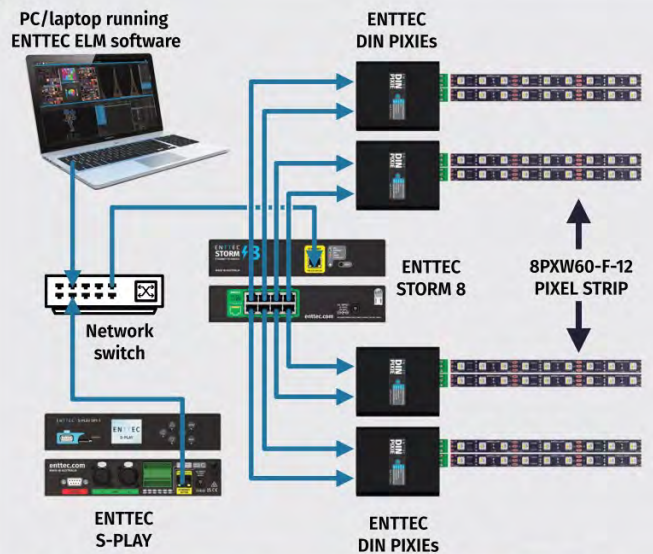
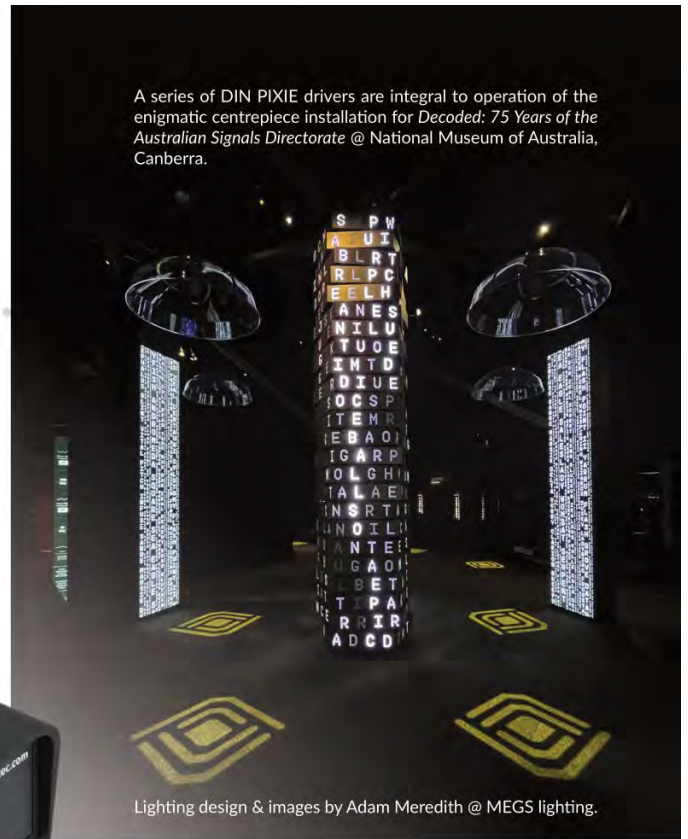
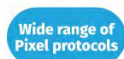

# PIXELATOR

SKU: 70060



Our flagship 48U Ethernet to PLink converter is known for its outstanding performance and perfect synchronisation across all 24 ports.

- > Control pixel strip or dots over a network
- > Compatible with many pixel protocols
- > 24 x 2-Universe PLink ports
- > Intuitive configuration via web browser
- > Gigabit Ethernet (100/1000 Mbps)
- > Dual core CPU + Ultra-fast DDR memory



DATA/POWER IN



DATA OUT



# PIXELATOR MINI

SKU: 70067



Smart and cost-effective, the Pixelator Mini is a compact 16-UNiverse rack, surface & DIN-rail mountable, eDMX to LED pixel converter.

- > Ethernet connection (10/100 Mbps)
- > Compatible with many pixel protocols
- > 8 x 2-Universe PLink ports
- > Can handle up to 2,720 RGB pixels
- > Intuitive configuration via web browser
- > EN-Case modular housing for easy rack, surface or DIN-rail mounting



DATA/POWER IN



DATA OUT



## PLINK INJECTOR

SKU: 73544 (12V-24V) / 73546 (5V)



The smartest way to connect and extend your pixel set-up, PLink injectors can be positioned as far as 300 metres from your Pixelator.

- > Works with the Pixelator series to extend pixel data over long distances
- > No configuration needed
- > Available in 5V & 12V-24V options
- > Requires external DC power supply
- > 10A maximum throughput



DATA / POWER IN



DATA / VOLTAGE OUT



SEE PAGES 6-7  
Learn how you can use the PLink system in conjunction with the Pixelator series for efficient control of LED pixel lighting.

## WATERPROOF PLINK INJECTOR

SKU: 73924 (IP66 PLINK INJECTOR)



With this waterproof pixel data injector, you can take your pixel strips outdoors and drive them like a pro in practically any conditions.

- > 'Outdoor' version of 73544
- > Works with the Pixelator series to extend pixel data over long distances
- > Controls up to 2U of pixel strip
- > Impact, corrosion and UV-resistant
- > Rated IP66



DATA / POWER IN



DATA / VOLTAGE OUT



# CVC4

SKU: 73926

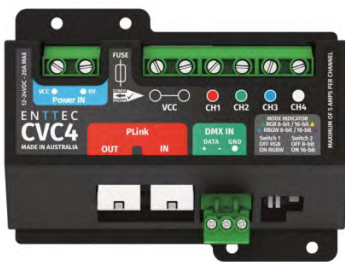

The CVC4 is an installation-grade constant voltage LED dimmer capable of dimming 4 x 5Amp outputs with up to 16-bit resolution (Choose from RGB 8-Bit, RGBW 8-Bit, RGB 16-Bit or RGBW 16-Bit). It can be addressed using RDM or ENTTEC's PLink protocol for quick, hassle-free commissioning. Requires an external DC power supply.



- > DMX/PLink input + RDM-addressable
- > Auto-addressable through ENTTEC's PLink system for simple commissioning
- > 5A per channel
- > User serviceable 20A fuse
- > 4 operating modes using DIP switches
- > Converts PLink data from your Pixelator
- > Flicker-free 1KHz dimming

### ENTTEC LED MAPPER (ELM) SOFTWARE

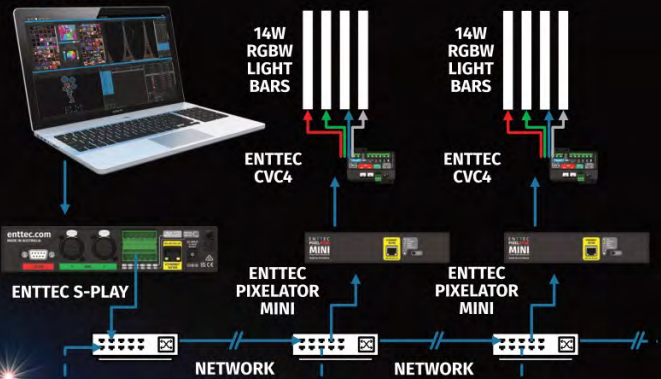

DATA/POWER IN

PLink 12-24v (20A)

DATA/VOLTAGE OUT

CV control tape 12-24 V

## CVC4 @ WORK

200 x CVC4s driving RGBW LED bars to light up Hobart's Tasman Bridge. Lighting design by Decrolux, working closely with Industrial Fire & Electrical (IF&E) & Hobart City Council.



**LED  
DOTS**

+

**S-PLAY**

smart light show controller



**The perfect pixel pair.**

Engineered to perfection by **ENTTEC**



SEE  
NEXT  
PAGE

SEE  
PAGE  
8

AUSTRALIAN  
DESIGNED + MADE

## Show Recorders

# S-PLAY

SKU: 70092



With intuitive, onboard controls to record, edit, schedule and play cues, you don't have to be an experienced lighting designer or systems integrator to conjure up amazing performances using the S-PLAY.

What's more, the S-PLAY doesn't just handle light shows: it can trigger non-lighting events too, opening up a new world of possibilities.

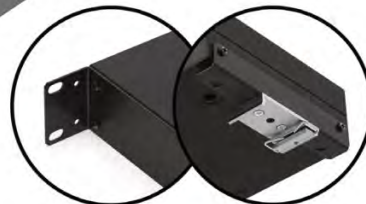

With countless applications from theatrical events to architectural design and smart home integration, automated show technology has never before looked so good, or been this easy to master.

- > Create, record, and edit shows
- > User-friendly web interface
- > Supports remote access over the internet
- > Trigger external events using a wide range of devices
- > Onboard LCD menu + USB for backing up shows
- > Expandable storage using the SD card slot
- > EN-Case modular housing for easy rack, surface or DIN-rail mounting

The S-PLAY's robust 1U half-width EN-Case modular hardware allows for a variety of surface, truss, rack and DIN rail mounting options straight out of the box thanks to its innovative design (mounting components included).



### DATA/POWER IN



### DATA OUT





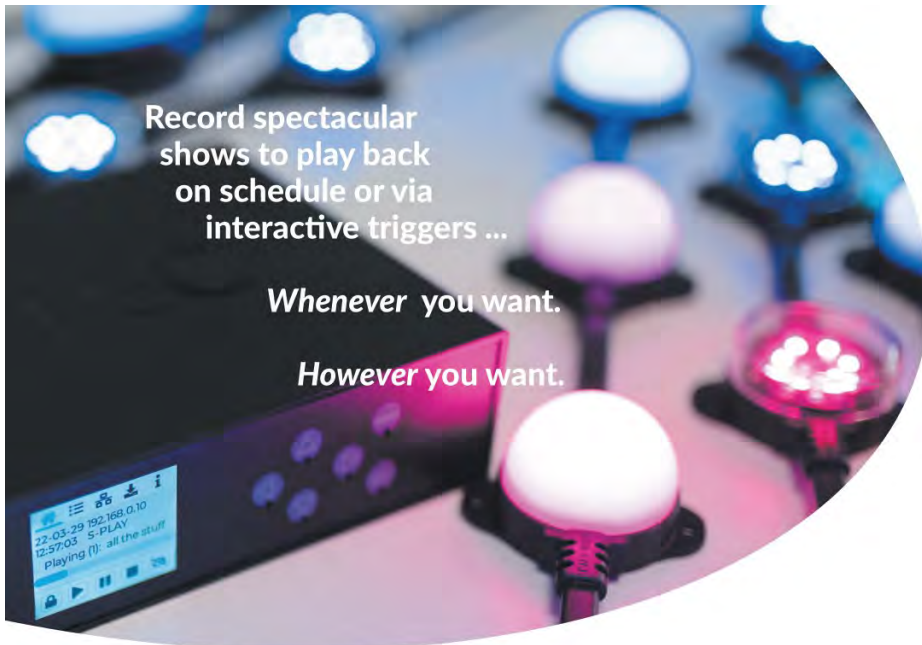

Record spectacular shows to play back on schedule or via interactive triggers ...

Whenever you want.

However you want.



## RECORD.

Use the web interface or multiple remote triggering options to record up to 32 eDMX universes or 2 universes of physical DMX. The S-Play contains smart features i.e. loop detection to ensure perfectly smooth looping.

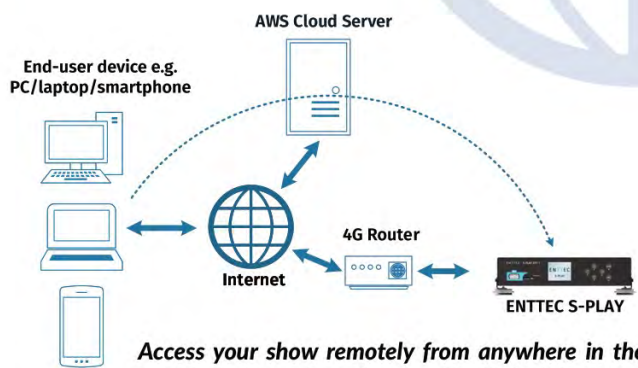

Access your show remotely from anywhere in the world via the internet using the S-PLAY's secure SSH connection!



## EDIT.

Using the intuitive timeline editor, multiple recordings and scenes can be stitched together while adding triggers and events to allow the S-PLAY to integrate into the heart of any control system.



## PLAY.

Play back multiple shows simultaneously from the internal scheduler, or when triggered in real time by building automation software (e.g. Control4), iPad Apps, pressure pads, motion detectors, push buttons and much more!



S-PLAY interface with new dark mode option.



## Next-Gen DMX lighting control for DJs + live musicians.



ENTTEC, one of the world's leading pioneers in entertainment lighting control technology, have worked alongside top musicians and audio engineers to bring you this state-of-the-art software designed to take your live performances to a new level.

By combining sound with light, you'll be able to create a fully-immersive experience for your audience and stay ahead of the competition ... without having to employ a lighting operator. It'll change the way your audience see you forever.

Even with no previous stage lighting experience, EMU is easy to use and will quickly give you the power to create outstanding atmospheres and visual effects to enhance your music, letting you focus on what you do best: hitting the right notes and putting on a good show!



**emu**  
SKU: 70680

### VST3 PLUGIN

Works with:

Ableton Live

FL STUDIO CUBASE  
+ more

EMU offers a Windows 32-bit or macOS 64-bit VST plugin capable of syncing the master playback state from your favourite DAW with the main EMU application, controlling program and bank changes directly from your DAW.

### REACTION TO LIVE AUDIO

EMU's Sound Tracker functionality allows you to set your lights to react directly to live audio in certain programs by taking an audio input from a soundcard, microphone or virtual loopback adapter to accentuate and give particular elements of your show an even greater impact.

EMU is a state-of-the-art, intuitive software package designed for live musicians to run automated or responsive light shows.

- > Modern UI design: easy to learn, simple to use
- > Tempo-based to sync with your music
- > Outputs 1 DMX universe (512 channels) connected using a DMX USB Pro or Art-Net
- > Control any DMX512 fixture: cloud-based database
- > VST plugin to control EMU from a DAW
- > MIDI input to change program
- > Footswitch input for easy operation on stage
- > Flexible licencing options

#### DATA IN



#### DATA OUT



#### PLATFORMS





Software

.....  
f e a t u r e s

### Hardware-style interface

Designed with live performances in mind, EMU's hardware-style user interface is quick to learn and easy to use. EMU's intuitive, tempo-based approach allows for the synchronisation of lighting and music with oscillators in real time.

With features such as lock, invert and duplicate along with a number of handy keyboard shortcuts, building your show is a breeze. Create static looks, dynamic chases & moving effects using virtual sliders to control each light's parameters.

Thanks to its 'bank and program'-based logic to store each look, EMU makes it familiar and easy for musicians to enter the world of lighting control without a steep learning curve.

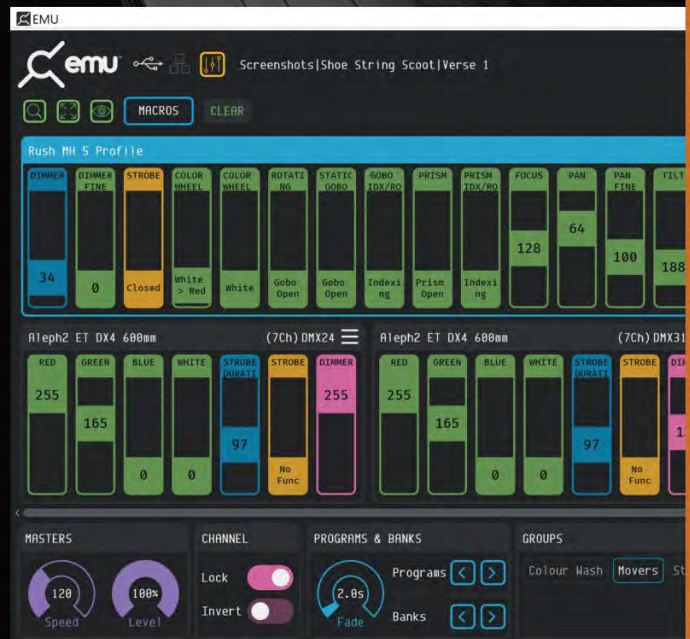

## ■ CONTROL ANY DMX-512 FIXTURE

Whether you want to control LED washes, moving heads, dimmer packs, smoke machines, scanners, moonflowers ... you name it, you can control them using EMU's DMX or Art-Net output.

ENTTEC has partnered with Crescit to give EMU a leading fixture library that receives regular updates. Crescit is a company with a background

in developing software to help professional lighting designers research, compile, manage and share production information and endeavours to add all known fixtures to their database.

With Crescit's vast fixture library integrated into EMU, this makes laboriously creating custom fixture profiles to control your equipment a thing of the past.

### MIDI integration

EMU's MIDI learn functionality allows controls to be mapped to physical MIDI control hardware or software applications with the use of a virtual MIDI loopback adaptor. When EMU has been linked to a MIDI input, toggling between the previous / next program or bank with external software is easy.

For users that want more direct control over every attribute in their show, EMU allows individual faders to be mapped to MIDI to control their level in real time for precise detail.

For those taking advantage of EMU's inbuilt oscillators, tap tempo can be set through MIDI CC or a MIDI clock signal can be used to set the global speed to synchronise all show file oscillators in real time.

### What else do I need?

You'll need a USB -> DMX interface or Art-Net node to connect lights to your computer. EMU works with ENTTEC's DMX USB Pros and Art-Net nodes.

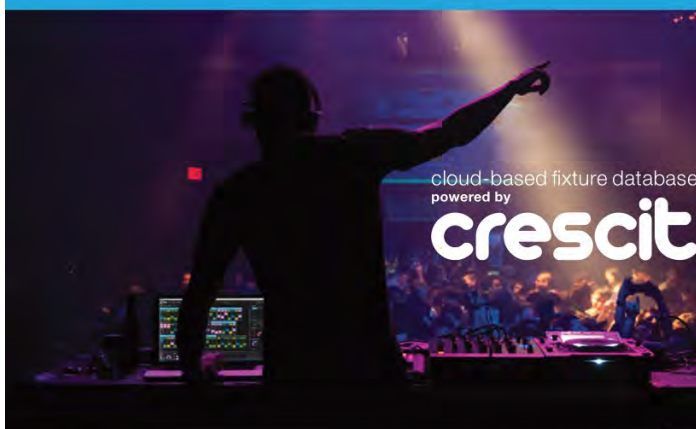

Software

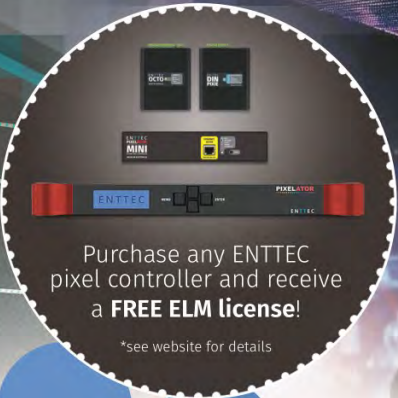

Purchase any ENTTEC pixel controller and receive a **FREE ELM license!**

\*see website for details



ELM @ Ipswich City Council tower, Queensland, Australia

**LIVEDESIGN**  
**LIGHTING**  
**CONTROL SOFTWARE**  
**PRODUCT**  
**2016-2017 OF THE YEAR**



# ENTTEC LED MAPPER (ELM)

SKU: 70581 (Licences: ENTRY: 4U / STANDARD: 16U / ADVANCED: 48U / PROFESSIONAL: 96U / SUPER: 256U / ULTIMATE: 512U / ARCHITECTURAL: 1024U / ELITE: 2048U)

Let your creativity soar with the versatility, power and precision of ENTTEC's award-winning, content-based LED mapping software.

- > Highly-intuitive interface
- > Huge generative effects library
- > Audio reactive mix feature
- > 2D & 3D mapping
- > Control up to 2048 Universes
- > Upgrade your license at any time
- > Proven track record of high-profile projects

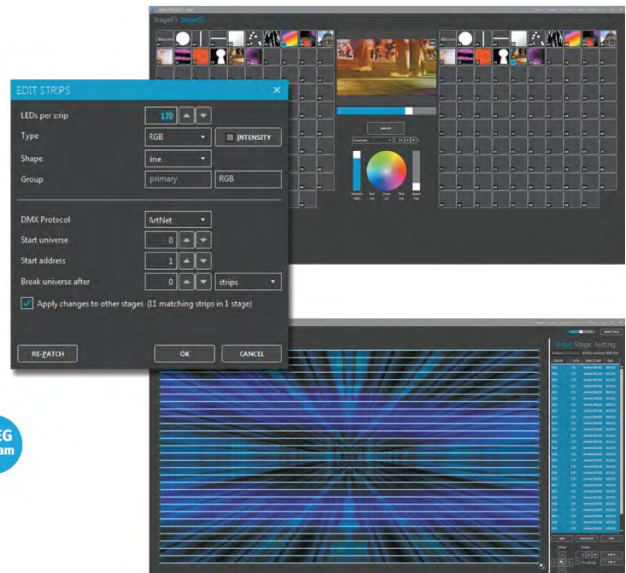

DATA IN



DATA OUT



PLATFORM



<sup>†</sup>using DMX USB Pro

**RECOMMENDED SYSTEM REQUIREMENTS:** Windows 8, 8.1 or 10, 2GHz or higher 4-core processor, 8GB RAM, NVIDIA 10 Series or higher graphics.

ELM combines raster-based media with vector-based, scalable and repositionable objects to represent your LED strips. Choose whether your LEDs are in a line, curve or full loop with just a few mouse clicks - then stretch, resize or move them around on-screen to match your strips in the real world.

Load and play back 4K or higher video files, generative effects, still images or display live streams using NDI, Spout, MPEG streams or physical capture cards. Thanks to ELM's inbuilt transcoder, media can be optimised for the most efficient playback. ELM supports scheduling, live playback and triggering from lighting consoles or 3rd party apps.

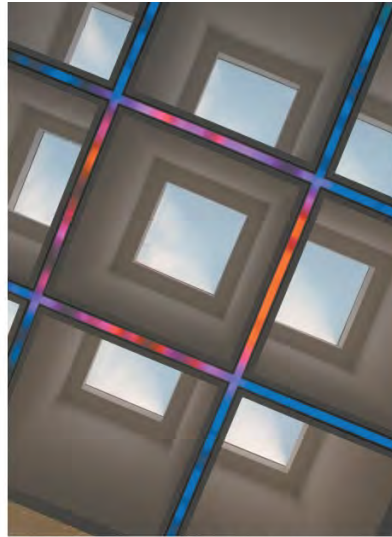

ELM @ The Glenwood, Raleigh, NC

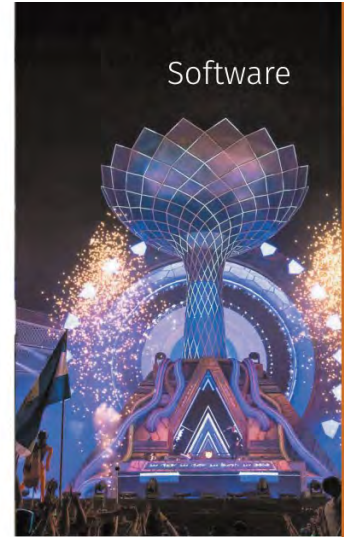

ELM @ Electric Daisy Carnival, Las Vegas

*"After reviewing a huge amount of options we found ELM to be the most intuitive and reliable application for the needs. It's clearly been designed by a team of people with a deep understanding of how a piece of software like this is actually used in the field. For a 6-week run, every night of the week during the British winter, it was rock solid."*

**Chris Evans-Roberts**  
 Founder & Creative Director, ITHACA



ELM @ Kew Gardens, London, UK - by ITHACA

With output support for Art-Net, sACN and KiNet, ELM works with a large number of ENTTEC and 3rd party lighting products. You can easily integrate ELM with your favourite control software using DMX, Art-Net, sACN, ENTTEC's DMX USB Pro, OSC or HTTP. ELM supports a wide range of LEDs such as RGB, BRG, RGBW, RGBWA and white in either 8- or 16-bit profiles.

### Optional support

ELM software runs on PC/Windows systems ONLY, but it can be controlled remotely by iOS devices using 3rd party software with the remote API's already integrated as standard.

Touch OSC by Hexler can allow recalling of states, or for a more complete implementation, ON LX's Ctrl for iPad allows ELM to be controlled as part of a wider installation with live thumbnails, creating a perfect customisable front-end interface for any installation requiring efficient editing on the run.





ENTTEC lighting control system in action @ Expo 2020 Dubai





ENTTEC Smart PXL 60 LED dots ~ by Illumidy @ historic Hop Lane, Ballarat, Australia



# ENTTEC LED lighting control video tutorial series



*"Just wanted to say thanks for all your videos - they are really appreciated. I've basically just binge watched the whole playlist and must admit I knew a lot of it, but it's good to remind oneself of all the points as well as pick up one or two new tips!"*

**Francois Ashton**  
Lighting designer

Say hello to Jordan, our intrepid Aussie electrical engineer.

As part of the R&D team at ENTTEC's Melbourne HQ, he gets to use his expert skills to solve a lot of problems and help design some of the LED and lighting control products that you all know and love. Jordan sure knows his stuff - and that's why we're excited to see him presenting our ongoing video tutorial series.

If you've ever wanted to learn the secret tips and tricks that professional lighting designers or installers use, simply join Jordan as he takes you through a variety of handy topics such as soldering, voltages, power supplies, fuses, software protocols and much more.

There's something for everyone, no matter what level of experience you have!

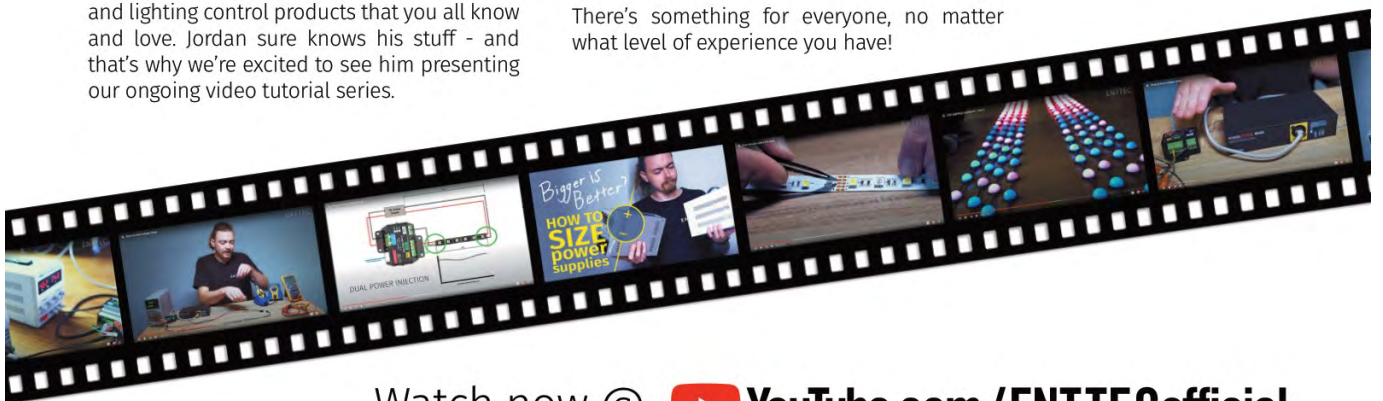

Watch now @  [YouTube.com / ENTTECOfficial](https://www.youtube.com/ENTTECOfficial)



## D-SPLIT

SKU: 70578 (2 x 3-PIN + 2 x 5-PIN) / 70579 (4 x 5-PIN)

An optically-isolated DMX splitter and repeater for DMX512, the D-SPLIT gives you the ultimate flexibility to link up to 32 fixtures.

- > 2 x 5-pin/2 x 3-pin or 4 x 5-pin options
- > Each output can support a DMX chain of up to 32 fixtures
- > Compatible with any DMX controller
- > Run four different optically-isolated DMX branches
- > Protects against 1000V of stray voltage



DATA IN

DMX

DATA OUT

DMX



70578 (2 x 3-PIN + 2 x 5-PIN)



70579 (4 x 5-PIN)

## DIN RDS4

SKU: 72004

The latest revision to our 4-port DIN-rail DMX/RDM splitter: a high quality, installation grade device in a slimmer, more compact enclosure.

- > 1 DMX/RDM input + 4 DMX/RDM outputs
- > DMX512-A & ANSI E1.20 RDM support
- > Electrically-insulated case material
- > Surface or TS35 DIN rail mount
- > No configuration required
- > 1500V Opto-isolation between each DMX port



DATA IN

DMX

RDM

DATA OUT

DMX

RDM

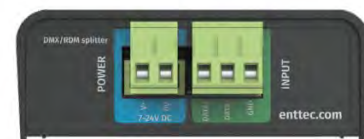

# STORM 8

SKU: 70056

A compact and powerful 8-port, multi-protocol Ethernet to DMX converter, the Storm 8 has been engineered for the smooth distribution of DMX universes. And with a little bit of creative thinking, it can even control far more than just lighting fixtures!

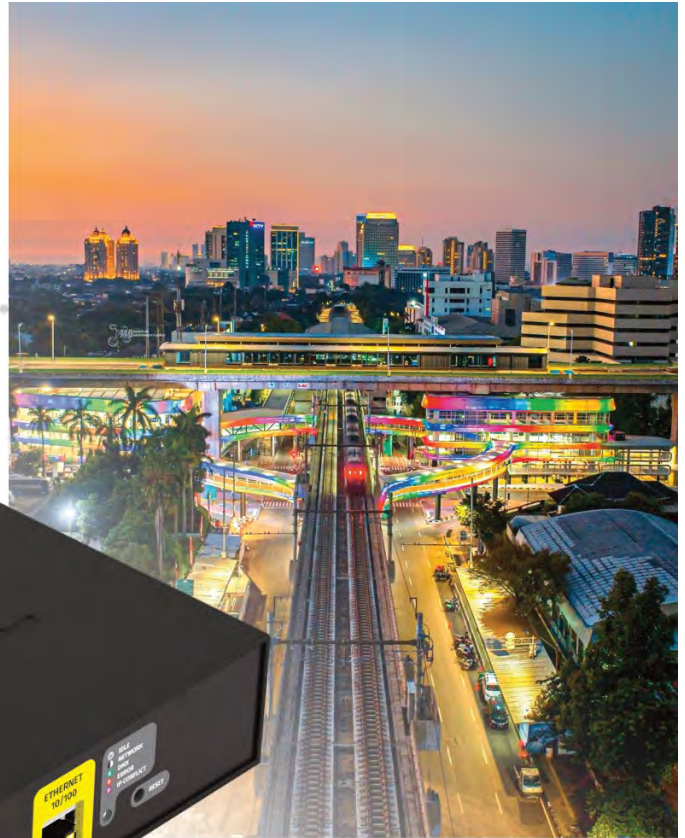

A series of STORM 8s played an integral role in conjunction with ENTTEC LED Mapper (ELM) and two ENTTEC S-PLAYs in the creation of this stunning circular LED skybridge installation at CSW-ASEAN TOD, Kebayoran Baru, South Jakarta, Indonesia. Has public transport ever looked as enticing as this before?

Project credit: PT Panasonic Gobel Eco Solutions Sales Indonesia, with lighting design and supply by PT Scienler Teknologi Indonesia.

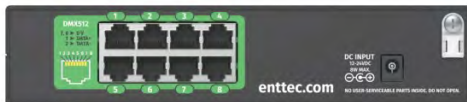

Convenient and easy to use, DMX outputs using RJ45 connectors (ANSI 1.27) are universally familiar to installers and require no soldering.

- > Multi-protocol support
- > Control up to 8 DMX universes
- > Easily configured via web browser
- > PoE or 12-24vDC power input options
- > Front LED status indicator
- > EN-Case modular housing for easy rack, surface or DIN-rail mounting

DATA IN



DATA OUT



# DIN ETHERGATE

SKU: 71030

The DIN Ethergate is ENTTEC's next evolution of the DIN ODE/POE units. Providing maximum value for money, the DIN Ethergate has two universes of bi-directional eDMX – DMX/RDM in a compact 4-module DIN-rail form factor.



The mechanical design has been simplified to provide a slimmer, more compact form while maintaining the performance that users have come to expect over the years.

- > Two bi-directional DMX/ E1.20 RDM ports
- > Support for Art-Net 4, sACN and ESP
- > HTP/LTP merging for up to 2 DMX sources
- > Surface or TS35 DIN rail mount
- > IEEE 802.3af PoE or DC 7-24v input
- > Intuitive configuration & web updates

DATA/POWER IN



DATA OUT



"We used the ENTTEC DMX USB PRO because of its compatibility with our main installation software. We've used this great little black box to power other Nike projects (and personal art projects). On this particular project, we controlled around 30 different custom LED fixtures with a bunch of them."

**Justin Gitlin (aka Cacheflowe)**  
Multimedia artist & software developer

3-storey tall multimedia sculpture for Nike's latest flagship retail hub in New York City, featuring multiple ENTTEC DMX USB PRO devices - by Cacheflowe / Hovercraft Studio

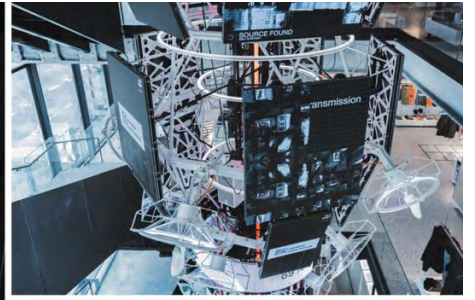
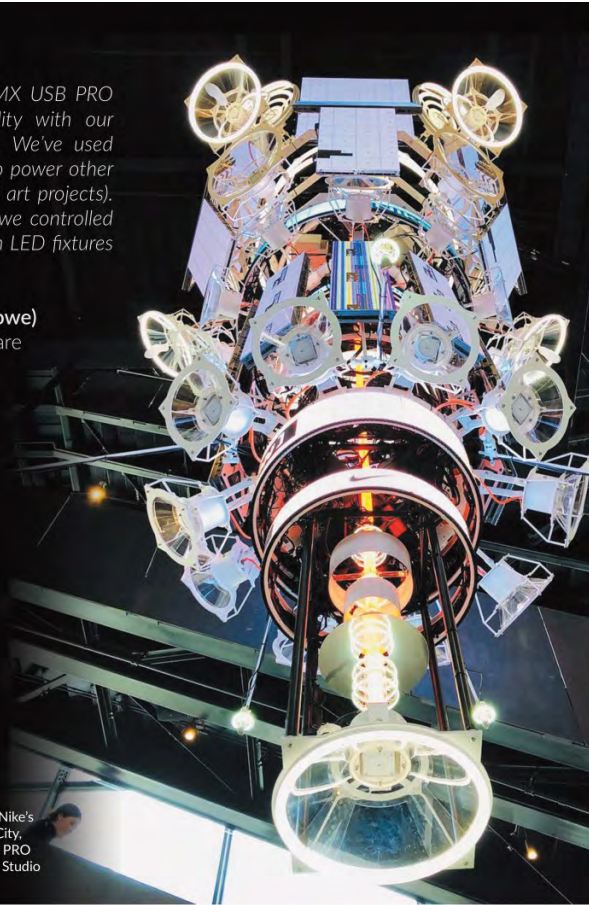

Pixelators / PLinks / ENTTEC pixel strips @ Toxic Avenger musical, London's West End - by White Light Ltd



Pixelators / PLink system @ The Royal Opera House, Copenhagen, Denmark ~ by Stig Debols

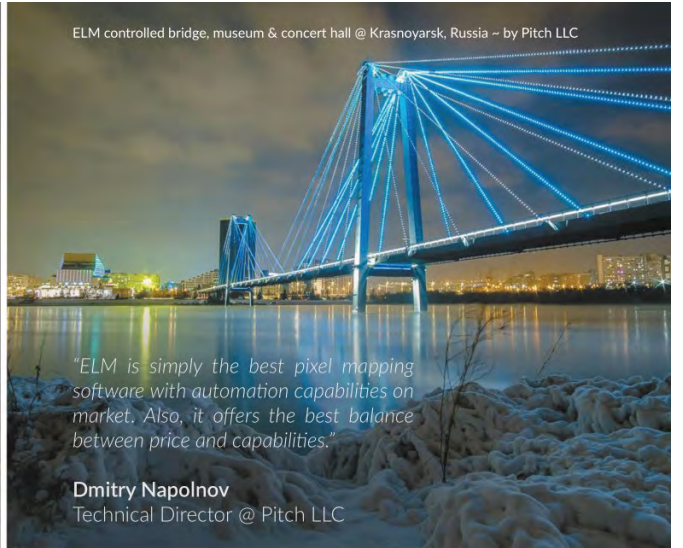

ELM controlled bridge, museum & concert hall @ Krasnoyarsk, Russia ~ by Pitch LLC

"ELM is simply the best pixel mapping software with automation capabilities on market. Also, it offers the best balance between price and capabilities."

**Dmitry Napolnov**  
Technical Director @ Pitch LLC



ELM & ENTTEC LED pixel strips @ Baroq House, Melbourne ~ by James Ady & Luke Stretton



ELM, Pixelator Mini, PLinks and LED strips @ Brisbane Powerhouse ~ by Nathen Street

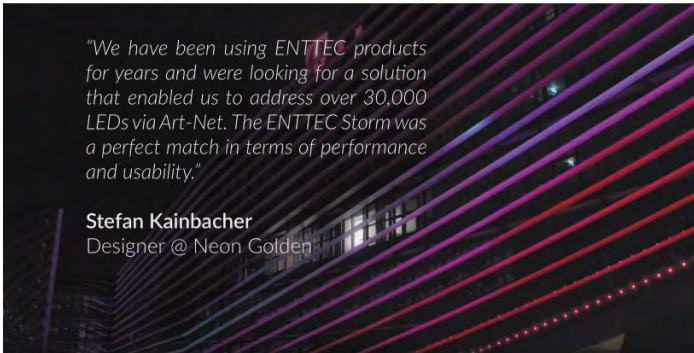

"We have been using ENTTEC products for years and were looking for a solution that enabled us to address over 30,000 LEDs via Art-Net. The ENTTEC Storm was a perfect match in terms of performance and usability."

**Stefan Kainbacher**  
Designer @ Neon Golden



ENTTEC Storm @ Magenta Telekom T-Center, Vienna, Austria ~ by Stefan Kainbacher



## ODE MK2

SKU: 70405 (ODE MK2) / 70306 (ODE MK2 WITH POE)\*

Supporting a wide range of protocols, the ODE (Open DMX Ethernet) MK2 has proven itself reliable and robust across many applications.

- > 1 Universe of DMX conversion
- > 10/100 Ethernet port with support for ArtNet/ArtRDM, sACN and ESP protocols
- > Factory set to use DHCP IP addressing
- > Use as a gateway between smart phone/tablet apps and your lighting
- > Easy to use web-based configuration

DATA/POWER IN



DATA OUT

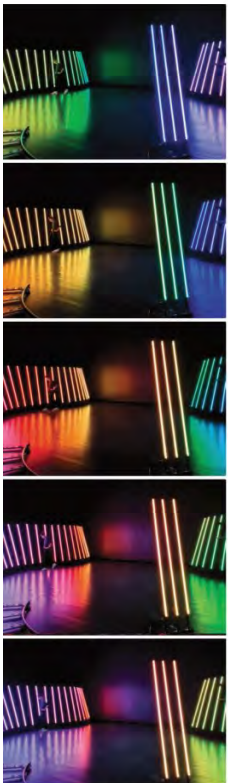

### IMMERSIVE ART

German entrepreneur Lars Hinrichs gives a press conference to announce the launch of Europe's first Digital Art Museum, set to open in Hamburg in 2024.

Lighting designer Maximilian Dickhaus used ENTTEC LED Mapper (ELM) to control these LED pixel bars during the livestreamed presentation.

Discover what ELM can do for your projects on p.28 of this booklet.



# DMX USB device comparison

*Features*  
↓

	OPEN DMX USB	DMX USB PRO	DMX USB PRO MK2
Part # (SKU)	70303	70304	70314
Max Output Channels	512 Channels	512 Channels	1024 Channels
DMX Out	Yes	Yes	Yes
DMX In	No	Yes	Yes
DMX Connector Type	5 pin DMX	5 pin DMX	5 pin DMX
Included Accessories	USB Cable	USB Cable	USB Cable DMX Breakout Cable
On-board Processing (timing and signal)	No. Dependent on the processing capabilities of your computer	Yes	Yes. 6 times faster than DMX USB Pro
Data & Power Line Isolation	No	1500V Isolation	1500V Isolation
Upgradeable Firmware	No	Yes	Yes
RDM Enabled	No	Yes. Requires firmware v2.4	Yes, with any firmware version
User Configurable (via PRO-Manager) Refresh Rate (1 to 40 Hz) Break Time (96 uS to 1.3 mS) MaB (10.6 uS to 1.3 mS)	No	Yes	Yes
Ability to Manage, Test, & Update (via PRO-Manager)	No	Yes	Yes
Standalone Playback	No	No	Yes. Limited to 1 universe
MIDI In/Out Ports	No	No	Yes, when supported by the software in use. Check with developer
MIDI Control Capability	No	No	Yes. DMX + MIDI cable sold separately
Choose your own lighting software?	Yes	Yes	Yes

*Who is it for?* →

- > Students
- > Novice users
- > Amateur productions
- > Troubleshooters



- > Community theatres
- > Medium-sized AV production companies
- > Nightclubs
- > Events



- > Large venues
- > Large audio-visual production companies
- > Trade shows
- > Installers



## OPEN DMX USB

SKU: 70303

Compatible with a wide range of applications, get into the world of DMX control from your computer with this affordable interface.

- > Compact size
- > Standard 5-pin DMX port
- > Outputs up to 512 DMX channels
- > Powered by your computer's USB
- > Compatible with popular apps
- > Integrate into your own software using the openly available API to output DMX



DATA IN



DATA OUT



## DMX USB PRO

SKU: 70304

Lightweight, portable and truly professional, the DMX USB PRO is the industry standard to control lights from your computer.

- > USB 2.0 support with status LED
- > 1500V full isolation
- > RDM enabled + Input or Output mode
- > Internal frame buffer for stable DMX generation
- > Widely supported by a huge range of commercial and free software



DATA IN



DATA OUT





# DMX USB PRO MK2

SKU: 70314

Next generation professional DMX to USB interface with 2 Universe (1024 channel) standalone playback mode.

- > USB 2.0 support
- > Two fully-isolated DMX/RDM inputs or outputs
- > True 1500V isolation for each DMX port
- > Configurable DMX properties
- > Record a light show and loop playback without having to connect to a computer



DATA IN



DATA OUT



## Control DMX lights with an OP-Z multimedia synth!

Aside from being able to make some cool sounds, one of the most pioneering features of teenage engineering's popular OP-Z multimedia synthesizer and sequencer is its ability to output DMX protocol in order to control lighting that can sync with your beats and visually take your performance to the next level.

To make this happen, grab yourself an ENTTEC DMX USB PRO or ENTTEC DMX USB PRO MK2 - the only two lighting interfaces recommended by teenage engineering.



Learn how it's done @ [enttec.com](http://enttec.com)



ENTTEC pixel dots / PLink system / Pixelator Mini @ Australian Open, Melbourne – by Landor / The P.A. People

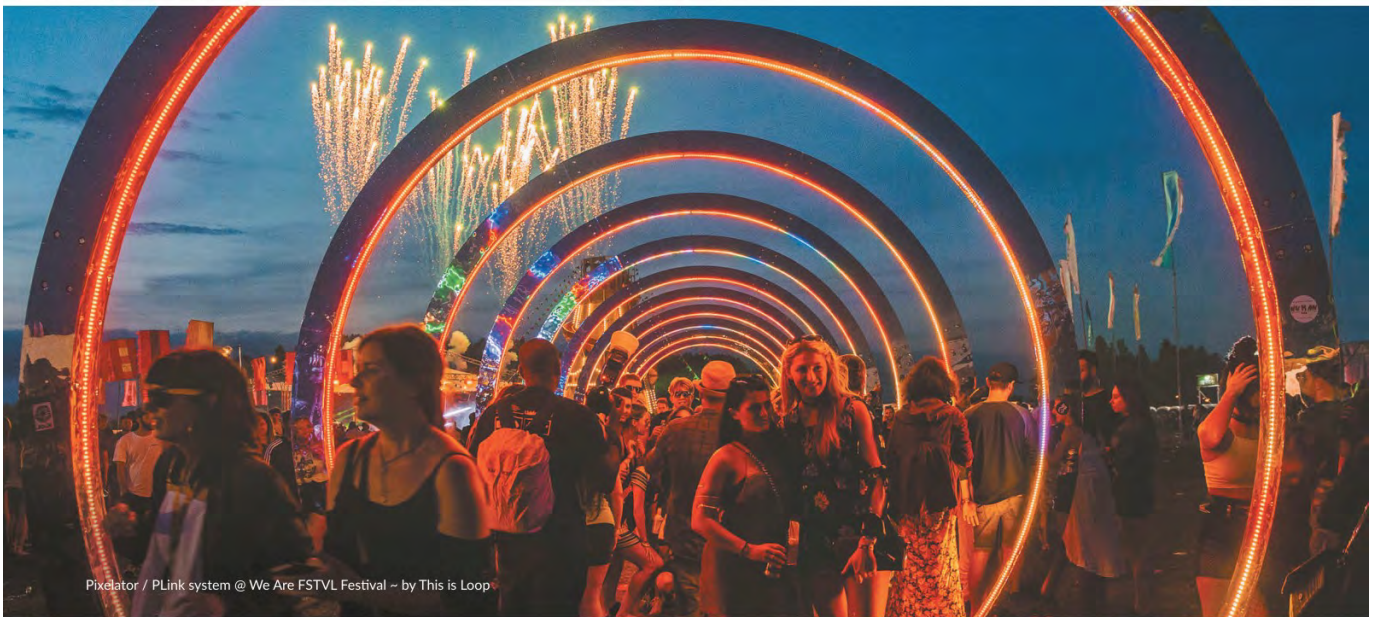

Pixelator / PLink system @ We Are FSTVL Festival – by This is Loop



ELM @ Electric Daisy Carnival, Las Vegas – by KrohTech



Pixelators, PLink system & ELM @ Glastonbury Festival ~ by Bailes + Light with ON LX



Pixelator Minis / PLink system @ Electric Picnic Festival, Ireland ~ by Luke Maguire

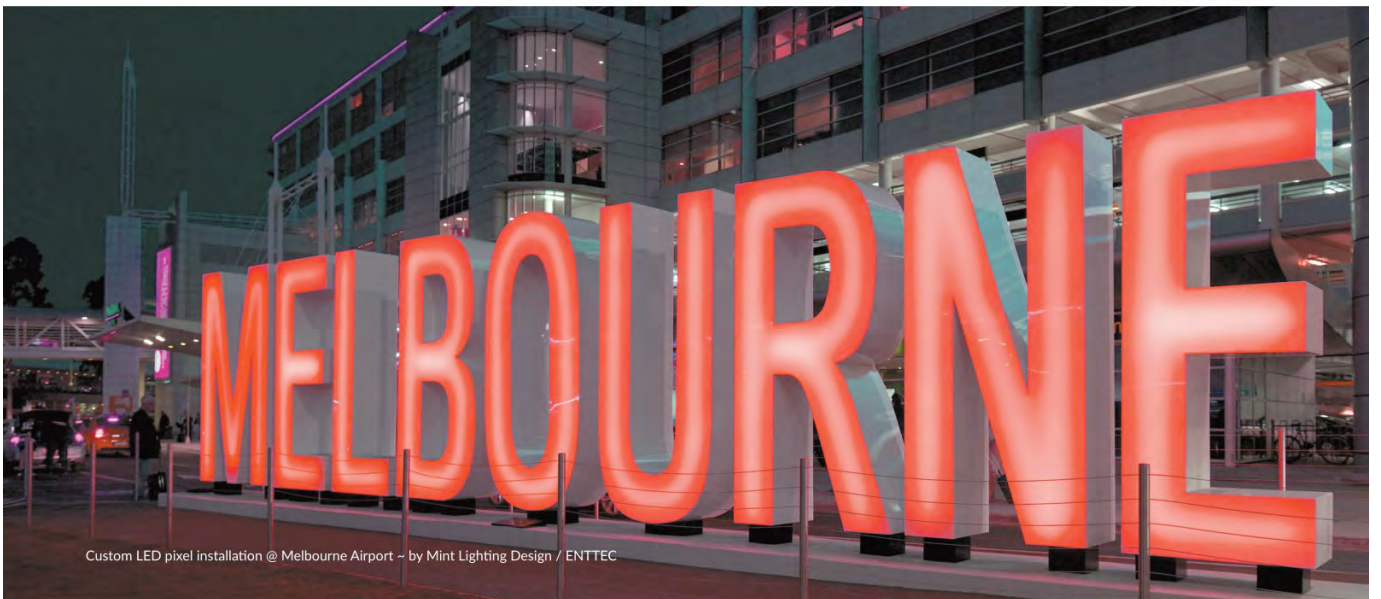

Custom LED pixel installation @ Melbourne Airport ~ by Mint Lighting Design / ENTTEC

This brochure is intended as an introductory guide to a number of core products from our constantly-evolving range.

Just as new products may become available and therefore not yet feature in this brochure, availability of existing products is also subject to change at any time, so please visit our website for the latest information.

Also, don't hesitate to contact us directly or ask your local dealer if you have any questions or require detailed technical specifications for any of the products featured within.

© ENTTEC 2022. While all reasonable care has been taken to ensure that the information presented within this publication is accurate as of the time of printing, it is intended as a guide only and ENTTEC shall not be held liable for any errors or omissions.

**enttec.com**  
MELBOURNE AUS / LONDON UK / RALEIGH-DURHAM USA