

SLAN
CITY-44

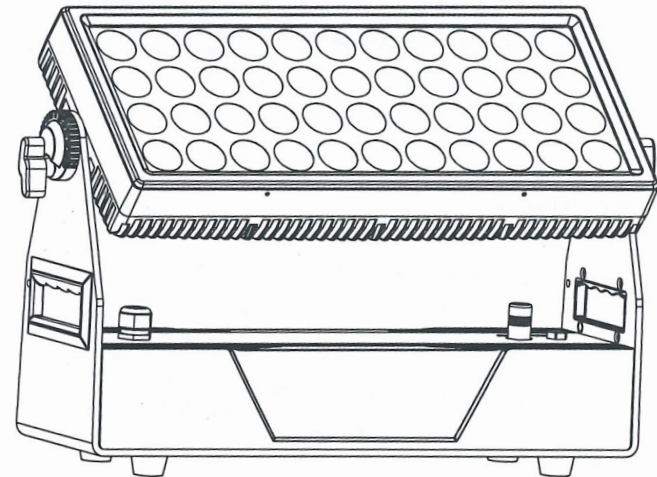

User Manual

Safety Introduction CITY-44

Before you operate this unit read the manual carefully. Always make sure to include the manual if you pass/rent/sell the unit to another user. Keep in mind that this manual cannot address all possible dangers and environments. Please use your own caution when operating. This product is for professional use only. It is not for household use.



- Do not operate the unit in areas of high temperature conditions. It will cause abnormal function or damage the product.
- Always use a suitable safety wire when mounting the light overhead.
- Connect the safety wire only to the intended safety mount.
- Always follow local safety requirements.



- Only qualified personnel may repair this product.
- Do not open the product housing.
- Do not apply power if the light is damaged.



- Do not directly look into the light.
- It can cause harm to your eyes.
- Do not look at the LEDs with a magnifying glass or any other optical instrument that may concentrate the light output.
- Please don't look at the light directly when the light's radiation temperature reach 40°C



- The exterior surfaces of the light can become hot, up to 55°C during normal operation.
- Ensure that accidental physical contact with the device is impossible.
- Install only in ventilated locations.
- Do not cover the light.



- Always charge with the flight case open.
- It is recommended to charge at a temperature between 15°C and 35°C



- Don't throw the unit into the garbage at the end of its lifetime.
- Make sure to dispose is according to your local ordinances and/or regulations, to avoid polluting the environment!
- The packaging is recyclable and can be disposed.



--2.0m | ta 45 °C

RDM---Remote Device Management

RDM is a wild version of the DMX512-A protocol, allowing dimming stations and other control devices to be discovered through a DMX512 network, and then configuring, status monitoring, and managing intermediate and line end devices.

It allows two-way communication between the lighting device or system controller and the connected RDM compatible device through the standard DMX. This protocol will allow these devices to be configured, monitored, and managed in a manner that does not interfere with the normal operation of standard DMX512 devices that do not recognize the RDM protocol.

Allow a controller or test device to find other devices that can be RDM, such as computer lights or dimming cabinets, and remotely manage them through this connection intelligence. Including the ability to remotely set the initial address of the DMX512, query the device's errors or statistics, and achieve most of the configuration settings that are usually done on the front panel of the device. RDM can run with the new RDM device or any original DMX512 product on the same data link without any performance impact. Since RDM runs on the first team DMX512 link, the only infrastructure upgrade required by RDM is to upgrade the existing data distributor to implement a two-way mode to support RDM.

The RDM information is transmitted through the first pair of DMX512 data channels. RDM uses packets that include non-zero initial codes to start and control communications. This alternating(rotating) session and waiting for indicative responses is performed in a semi-duplex format. The second data pair is not used for any RDM function.

Two-way data transmission-each vendor's equipment can exchange data, Art-net can only transmit data, can not exchange with each other.

Its functions are as followed:

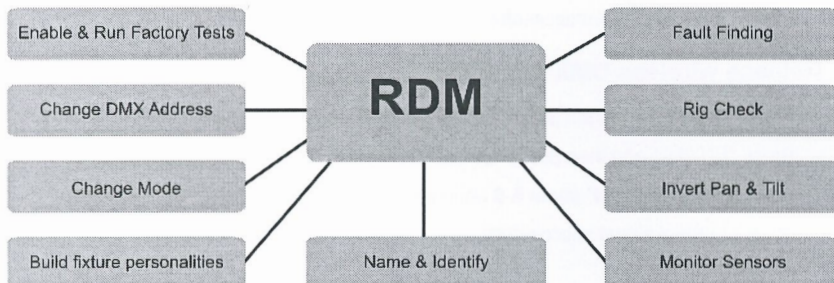

Product Overview

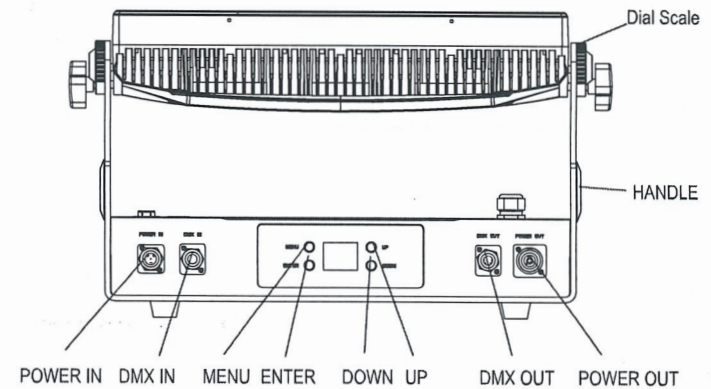
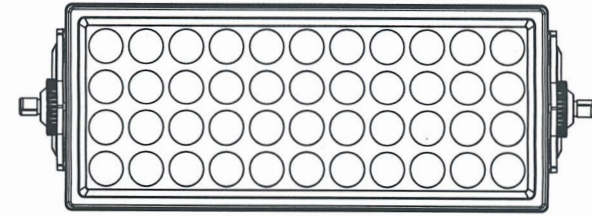

Mechanical Specification

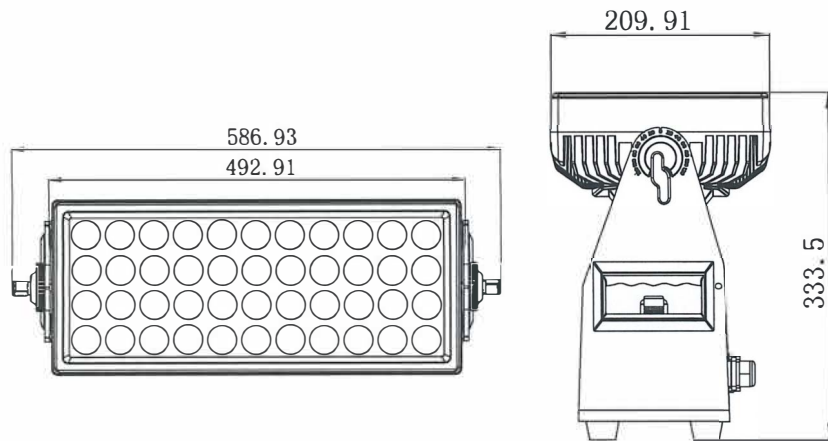

Accessory

- ① Magnetic frost filter 40° & 10x60° (optional)
- ② Barndoor x 1 (optional)
- ③ 1/4 turn fast lock x 2
- ④ Power cable x 1

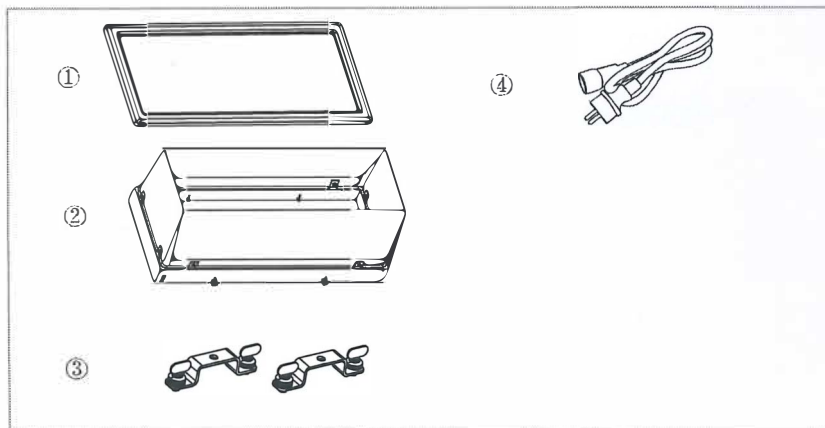

Connection

DMX connection

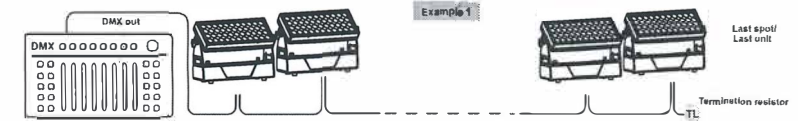

Master / Slave connection



Wireless connection(No function)

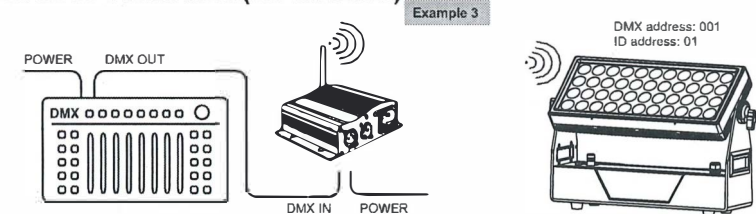

Connection(No function)

Press "ENTER" and then press "UP" or "DOWN" to "SET UP" .

Press "ENTER" and then press "UP" or "DOWN" to "Wireless rel" is displayed, press "ENTER".Then press "DMX Mode" is ok.

Then, until Green wireless signal is showed. Then Wireless DMX connected success.

About the condition of wireless signal, green means the setting is successful,red means the signal is unsuccessful.

Release wireless DMX signal(No function)

Press "ENTER" and then press "UP" or "DOWN" to "Wireless rel".

Press "ENTER" and then press "UP" or "DOWN" to "Release +/-",and then long press "UP" or "DOWN" about 5-6 seconds. Until "clear is success" is showed. It means release signal successfully.

CABLE CONNECTORS

Cabling must have a male XLR connector on one's end and a female XLR connector on the other's end.

DMX connector configuration

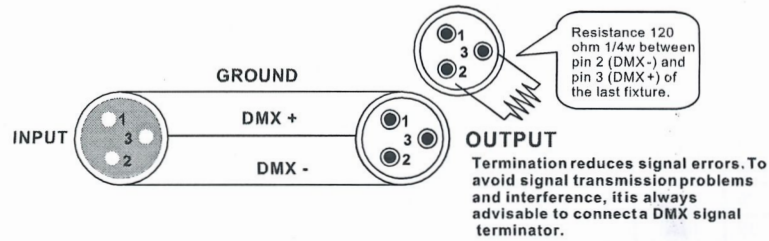

Caution: Do not allow contact between the ground and the fixture's chassis ground. Grounding the ground can cause a ground loop, and your fixture may perform erratically. Test cables with an ohm meter to verify positive pole and to make sure the pins are not grounded or shorted to the shield or each other.

3-PIN TO 5-PIN CONVERSION CHART

Please note if you use a controller with a 5 pin DMX output connector, you need to use a 5 pin to 3 pin adapter. The chart below details a proper cable conversion:

3-PIN TO 5-PIN CONVERSION CHART

Conductor	3 Pin Female (output)	5 Pin Male (Input)
Ground/Shield	Pin 1	Pin 1
Data (-) signal	Pin 2	Pin 2
Data (+) signal	Pin 3	Pin 3
Do not use		Do not use
Do not use		Do not use

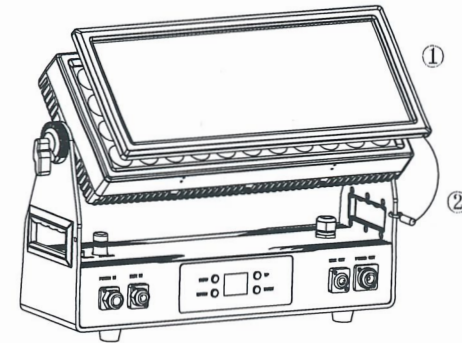

If you want to set up the magnetic frost filter, please follow the steps as below:

1. Please put the magnetic frost filter onto the top cover of the lights. Please don't worry about the filter will be fallen down, because the top cover and the filter are have magnets.
2. Please put the hook of the safety rope hangs on the hole of the handle of the light. Please make sure the safety rope on the side of the screen then the hook can be hung.

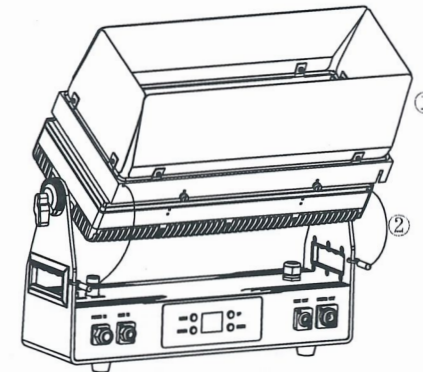

If you want to set up the barndoor, please follow the steps as below:

1. There are 4 holes on the top cover of the lights, please put the screws of the barndoor to connect these 4 holes then tighten them.
2. Please put the hooks of the two safety ropes hang on the holes of the handles of the light. Please make sure the safety rope on the side of the screen then the hook can be hung.

Optical output : 9166 lm

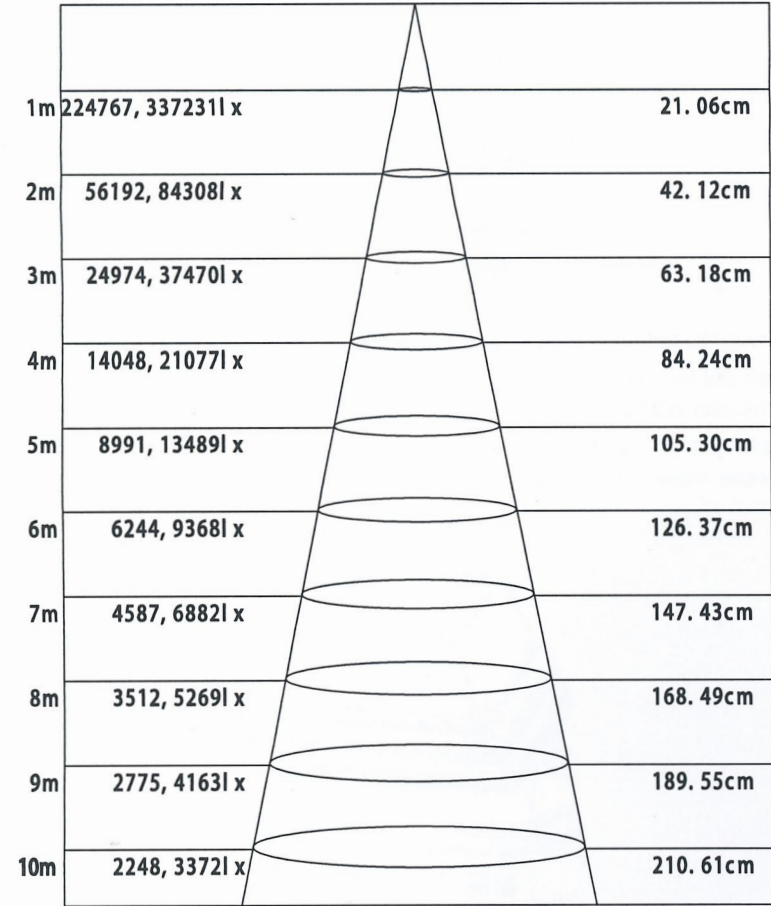

Beam angle: 12.02°

Noted: This curve is explained by the irradiation area and it's average illumination of different projection distance of the light.

Channel 19 (Id address set)

0-9	all lds	170-179	ld17	223	ld34	240	ld51
10-19	ld1	180-189	ld18	224	ld35	241	ld52
20-29	ld2	190-199	ld19	225	ld36	242	ld53
30-39	ld3	200-209	ld20	226	ld37	243	ld54
40-49	ld4	210	ld21	227	ld38	244	ld55
50-59	ld5	211	ld22	228	ld39	245	ld56
60-69	ld6	212	ld23	229	ld40	246	ld57
70-79	ld7	213	ld24	230	ld41	247	ld58
80-89	ld8	214	ld25	231	ld42	248	ld59
90-99	ld9	215	ld26	232	ld43	249	ld60
100-109	ld10	216	ld27	233	ld44	250	ld61
110-119	ld11	217	ld28	234	ld45	251	ld62
120-129	ld12	218	ld29	235	ld46	252	ld63
130-139	ld13	219	ld30	236	ld47	253	ld64
140-149	ld14	220	ld31	237	ld48	254	ld65
150-159	ld15	221	ld32	238	ld49	255	ld66
160-169	ld16	222	ld33	239	ld50		

Value		color temperature
1	23	2500K
24	47	3000K
48	71	3500K
72	95	4000K
96	119	4500K
120	143	5000K
144	167	6000K
168	191	7000K
192	215	8000K
216	239	9000K
240	255	10000K

Displayer Introduction

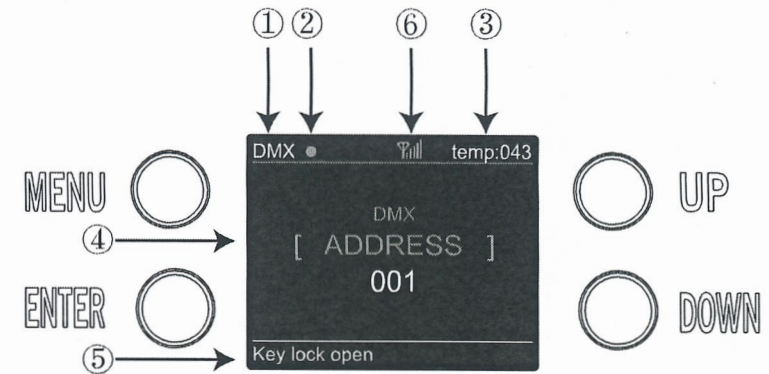

1. When you enter DMX Mode, it will be shown DMX, when you enter SLAVE Mode, it will be shown SLAVE.
2. This shows the condition of signal transmission. Green is connected. Red is disconnected.
3. This shows the temperature of the lights.
4. This shows the menus you can select.
5. This shows the condition of key lock. "Key lock open" means it is open and "Key lock off" means it is close.
6. This shows the condition of wireless signal. Green is connected. Red is disconnected. (No function)

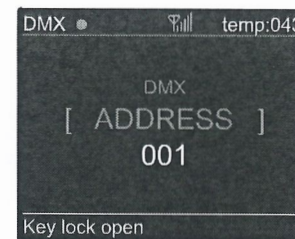

While DMX and Wireless signal are green, it means DMX Mode and Wireless are connected.



While DMX shows red but Wireless signal shows green, it means DMX Mode is disconnected and Wireless is connected.



While DMX shows green but Wireless signal shows red,it means DMX Mode is connected and Wireless is disconnected.

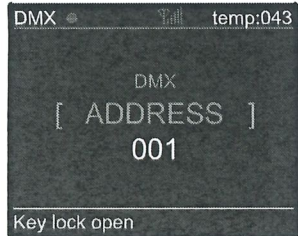

While DMX and Wireless are show red,it means DMX Mode and Wireless are disconnected.



While the letters and number shows change from white to yellow,it means the temperature beyond max temperature of default settings.

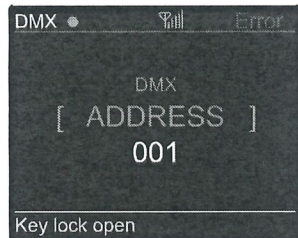

While the letters and number shows Error,it means have some problems of temperature.

Value		Color	Value		Color
0	7	Null	112	114	Color 36
8	9	Color 1	115	117	Color 37
10	12	Color 2	118	120	Color 38
13	15	Color 3	121	123	Color 39
16	18	Color 4	124	126	Color 40
19	21	Color 5	127	129	Color 41
22	24	Color 6	130	132	Color 42
25	27	Color 7	133	135	Color 43
28	30	Color 8	136	138	Color 44
31	33	Color 9	139	141	Color 45
34	36	Color 10	142	144	Color 46
37	39	Color 11	145	147	Color 47
40	42	Color 12	148	150	Color 48
43	45	Color 13	151	153	Color 49
46	48	Color 14	154	156	Color 50
49	51	Color 15	157	159	Color 51
52	54	Color 16	160	162	Color 52
55	57	Color 17	163	165	Color 53
58	60	Color 18	166	168	Color 54
61	63	Color 19	169	171	Color 55
64	66	Color 20	172	174	Color 56
67	69	Color 21	175	177	Color 57
70	72	Color 22	178	180	Color 58
73	75	Color 23	181	183	Color 59
76	78	Color 24	184	186	Color 60
79	81	Color 25	187	189	Color 61
82	84	Color 26	190	192	Color 62
85	87	Color 27	193	195	Color 63
88	90	Color 28	196	198	Color 64
91	93	Color 29	199	201	Color 65
94	96	Color 30	202	204	Color 66
97	99	Color 31	205	207	Color 67
100	102	Color 32	208	210	Color 68
103	105	Color 33	211	213	Color 69
106	108	Color 34	214	216	Color 70
109	111	Color 35	217	219	Color 71
			220	255	Color 72

19CH		
channel	value	function
1	000 - 255	Dimmer
2	000 - 255	dimmer 16 bit
3	000 - 255	Strobe from slow to fast
4	000 - 255	Red
5	000 - 255	Red 16 bit
6	000 - 255	Green
7	000 - 255	Green 16 bit
8	000 - 255	Blue
9	000 - 255	Blue 16 bit
10	000 - 255	White
11	000 - 255	White 16 bit
12	000 - 255	Amber
13	000 - 255	Amber 16 bit
14	000 - 255	UV
15	000 - 255	UV 16 bit
16	000 - 255	Dimmer Speed
17	000 - 255	auto
18	000 - 255	auto Speed
19	000 - 255	id address

Features

OPTICALS

- Light Source: 44*20W, 4 in 1 RGBWAUV LEDs
- Lens: 15°

ELECTRICAL

- Power consumption: 820W
- Voltage: 100-240V 50/60Hz

CONTROL

- DMX channels: 2, 3, 6, 11 & 19 CH
- Run Mode: DMX 512 /Slave/Auto Run Mode
- Built-in Effect: color mixing, variable color chasing, strobing and fading.
- Maximum 66 ID setting for easy separately control

SOFTWARE

- 11 customerize programs
- 4 different dimming curve
- Smart temperature control
- Working time record

PHYSICAL

- Material: Aluminum body
- Painting: an-ti salt & an-ti UV
- LCD displayer with four buttons
- Key lock for buttons
- IP65
- Temperature: -40 C ~45 C
- N.W: 13.5 KG
- G.W: 17.5 KG
- Dimensions: 575 x 210 x 334 mm

Programme Menu

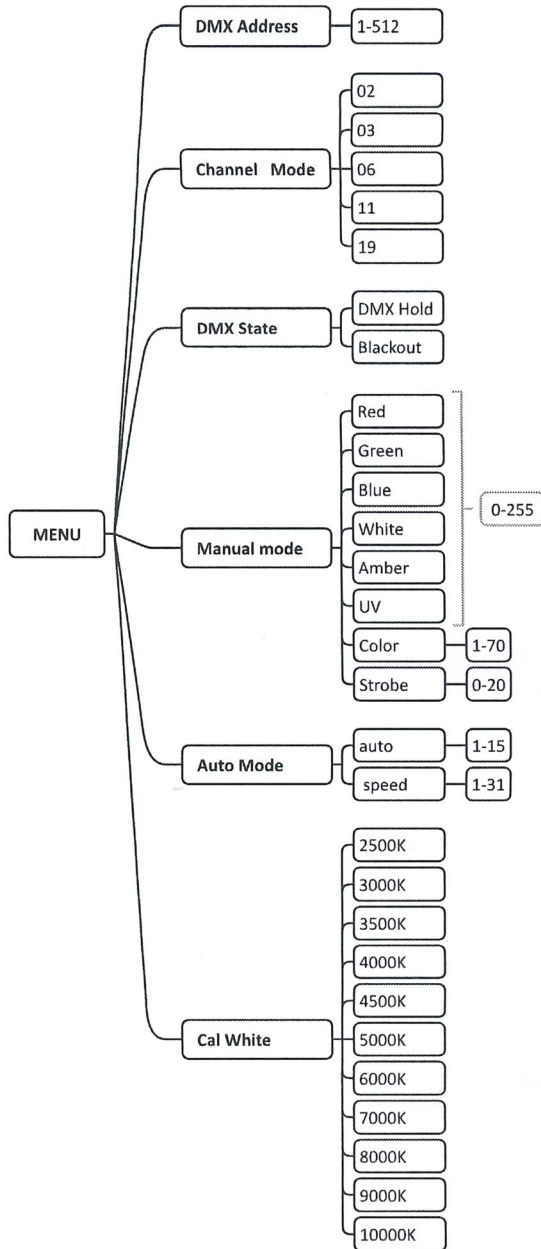

11CH		
channel	value	function
1	000 - 255	Dimmer
2	000 - 255	Strobe from slow to fast
3	000 - 255	Red
4	000 - 255	Green
5	000 - 255	Blue
6	000 - 255	White
7	000 - 255	Amber
8	000 - 255	UV
9	000 - 049	No function
	050 - 099	Dimmer Speed 1
	100 - 149	Dimmer Speed 2
	150 - 199	Dimmer Speed 3
	200 - 255	Dimmer Speed 4
10	000 - 007	No function
	008 - 017	auto 1
	018 - 027	auto 2
	028 - 037	auto 3
	038 - 047	auto 4
	048 - 057	auto 5
	058 - 067	auto 6
	068 - 077	auto 7
	078 - 087	auto 8
	088 - 097	auto 9
	098 - 107	auto 10
	108 - 117	custom 1
	118 - 127	custom 2
	128 - 137	custom 3
	138 - 147	custom 4
	148 - 157	custom 5
	158 - 167	custom 6
168 - 177	custom 7	
178 - 187	custom 8	
188 - 197	custom 9	
198 - 207	custom 10	
208 - 255	custom 11	
11	000 - 255	auto Speed

DMX control mode

2ch		
channel	value	function
1	000 - 255	Color 1-72
2	000 - 255	White(2500K-10000K)

3ch		
channel	value	function
1	000 - 255	Hue
2	000 - 255	Saturation
3	000 - 255	Value(brightness)

6 CH		
channel	value	function
1	000 - 255	Red
2	000 - 255	Green
3	000 - 255	Blue
4	000 - 255	White
5	000 - 255	Amber
6	000 - 255	UV

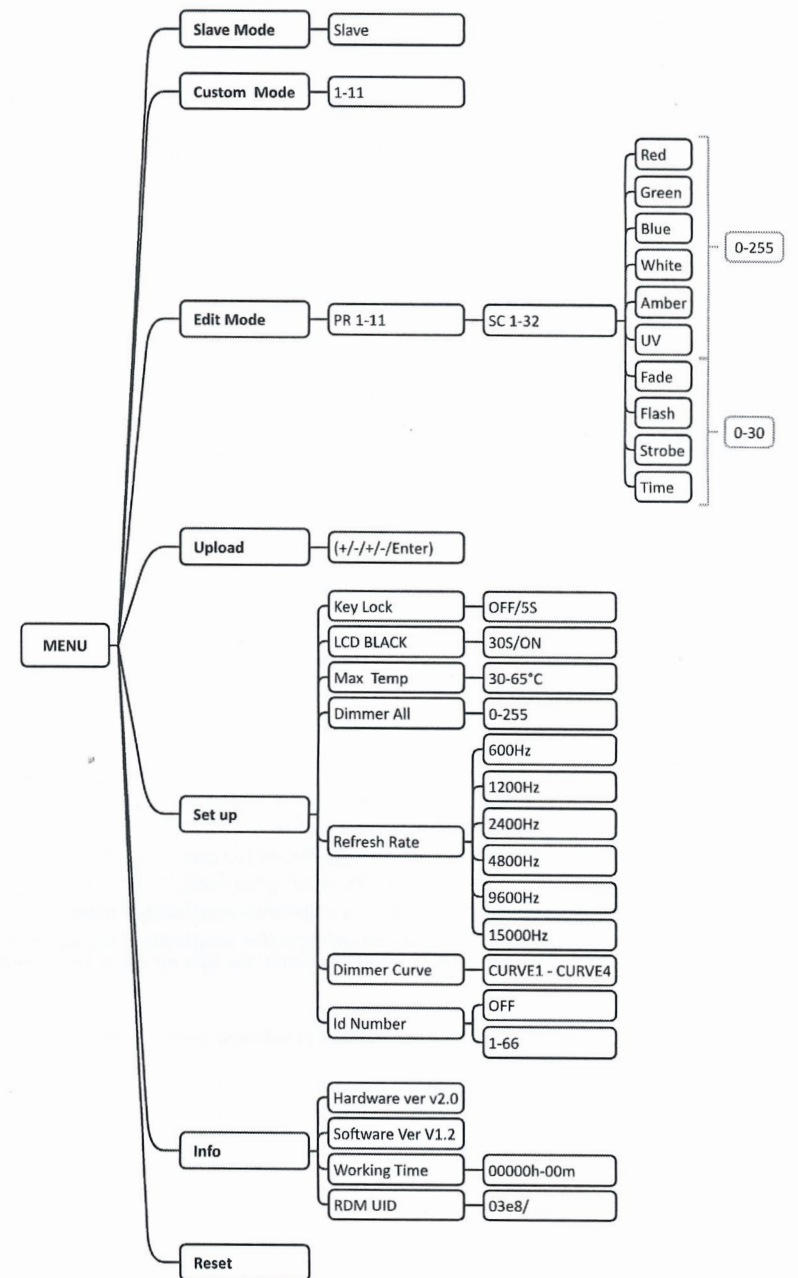

Operation

DMX Address and Channels Mode-In this menu,you can connect several pieces of lights with DMX cable and control them with control console.

1. Press "ENTER" button and then UP or DOWN button,Until "Channels Mode" or "DMX Address" will be showed.Then press ENTER.

1) "Channel [xx]" will be showed, "X" represents the showed DMX channel mode. You can press the UP or DOWN button to select your desired Channel mode.

2) "xxx" will be showed, "x" represents the showed address. You can press the UP or DOWN button to select your desired address.

SLAVE MODE-In this menu, you can select one light as the MASTER light(In DMX Mode) and other lights in SLAVE mode will run following the MASTER light.

1. Press "ENTER" button and "Slave MODE" is showed.

2. Press "ENTER" button, and "SLAVE" will be showed, then press ENTER.

DMX STATE - In this menu, you can select the DMX STATE of lights.

1. Press "ENTER" button and then UP or DOWN button until "DMX STATE" is showed.

2. Press "ENTER" button, and there will be two options. Then, press ENTER to select the option and press UP or DOWN button to select the value you desire as follow:

1) DMX HOLD – You can keep the DMX mode;

2) BLACKOUT - You can blackout the DMX mode so that you can set other mode you desired.

SET UP-In this menu, you can choose from 8 different functions according to your needs.

1. Press "ENTER" button and then UP or DOWN button until "SET UP" is showed.

2. Press "ENTER" button, and there will be 8 options. Then,press ENTER to select the option and press UP or DOWN button to select the value you desire as below.

1)LCD BLACK - In this item, you can select "ON" or "30S". If you select "ON", the display will be on all the time. And if you select "30S", the display will off about 30s later.

2) Key lock - If you choose 5S ,the display will lock after 5S.

3) RDM UID - In this menu,enter the password [up]+[down]+[up]+[down], the RDM information is displayed.

4) ID number - You can select an ID Number in this menu.Then, you can adjust the value of channel 12 to the corresponding scope and control the light individually with control console.

5) Dimmer Curve-You can choose 4 kinds of curves as you want.

6) Rate-You can choose the refresh rate from 600Hz to 9600Hz as you want.

7) Dimmer ALL - You can adjust the brightness from 000 to 250 in this menu.

8) Max temp - You can set the your desired Max working temperature about the light in this

menu.When the working temperature of the light exceeds the Max temperature, the color of letter "Temp xx" showed in the menu will change from white to yellow.Meanwhile, the light will adjust the working temperature automatically.

INFO-In this menu, you can learn about the information of software, hardware,RDM and the working time of the light.

1. Press "ENTER" button and then UP or DOWN button until "INFO" is showed.

2. Press "ENTER" button, and"Software", "Hardware", "RDM UID" and "working time" will be showed.

1) Software - This item shown the Software information.

2) Hardware - This item shown the Hardware information.

3) Working times - This item shown the working hours about the light.

4) RDM UID - This item shown the RDM of light.

AUTO-In this menu, you can select your desire AUTO mode and adjust the running speed.

1. Press "ENTER" button and then UP or DOWN button until "AUTO MODE" is showed.

2. Press "ENTER" button, and "SPEED" or "AUTO MODE" will be showed. Then press ENTER,and you can see two items as below:

1) SPEED - You can select your desired speed from 01-31 in this menu.

2) AUTO MODE - You can select your desired auto mode from 01-15 in this menu.

CUSTOMER MODE-In this menu,you can select the AUTO program edited in the "EDIT" menu.

1. Press "ENTER" button and then UP or DOWN button until "Customer Mode" is showed.

2. Press "ENTER" button, and there are 11 pre-programmed mode edited in the "EDIT" menu.

CAL WHITE-In this menu, you can adjust the value of 11 different white color.

1. Press "ENTER" button and then UP or DOWN button until "CAL WHITE" is showed.

2. Press "ENTER" button, and you'll have 11 different white colors to choose from.

Manual Mode-In this menu, you can adjust the value of static color and strobe speed as you like.

1. Press "ENTER" button and then UP or DOWN button until "Manual Mode" is showed.

2. Press "ENTER" button, and there are six options. Then press ENTER to select the option and press UP or DOWN button to select the value you desire as below:

1) RED - You can adjust the red brightness in this menu.

2) GREEN - You can adjust the green brightness in this menu.

3) BLUE - You can adjust the blue brightness in this menu.

4) WHITE - You can adjust the white brightness in this menu.

5) COLOR -You can select 70 static color in this menu.

6) STROBE - You can adjust the strobe speed in this menu.

EDIT MODE-In this menu, you can edit your desired AUTO program.

1. Press "ENTER" button and then UP or DOWN button until "EDIT MODE" is showed.

2. Press "ENTER" button, and open the "EDIT" mode to edit the custom programs from"PR.01" to "PR.11".And there are 32 scenes that can be edited in each custom program.

3. You can edit a scene by adjusting the value of "RED (0~255)", "GREEN (0~255)", "BLUE (0~255)", "WHITE (0~255)", "FADE (0~30)", "FLASH(0~30)", "STROBE (0~30)" & "TIME (0~30)" as you like. Then the data will be saved, when you press the ENTER button for 5 seconds.

UPLOAD-In this menu,you can connect several pieces of lights with MAX cables and set one light as the MASTER and others in SLAVE mode.Then upload the custom program in the MASTER light to the lights in SLAVE mode.

1. Press "ENTER" button and then UP or DOWN button until "UPLOAD" is showed.

2. Press "ENTER" button to upload the custom programs from the MASTER light to the SLAVE ones.

Wireless-In this menu, you can turn the wireless on or off.(NO FUNCTION)

1. Press "ENTER" button and then UP or DOWN button until "Wireless" is showed.

2. Press "ENTER" button and you can choose on or off.

Release-In this menu, You can clear the wireless signal.(NO FUNCTION)

1. Press "ENTER" button and then UP or DOWN button until "Release" is showed.

2. Press "ENTER" button and you can choose + or-.

Factory Reset-In this menu, you can reset all the value of the system.

1. Press "ENTER" button and then UP or DOWN button until "Factory Reset" is showed.

2. Press the ENTER button to reset all the value of the system.