

User manual

SLAN

ATLAS-18

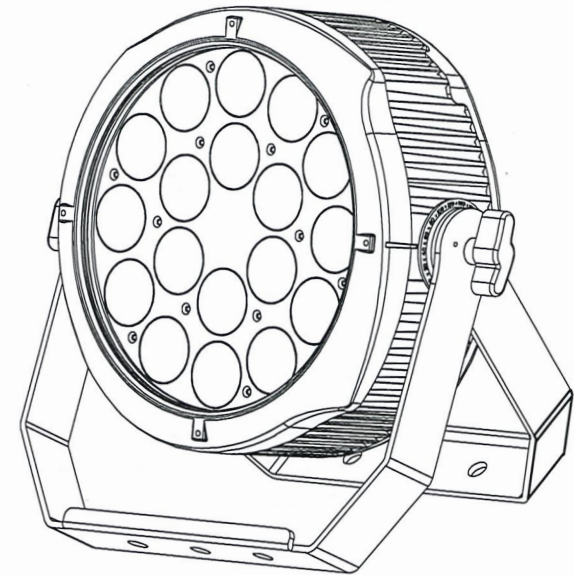

Please read carefully before use

Please Note: Specifications and improvements in the design of this unit and this manual are subject to change without any prior written notice.

Packaging: Thanks for your purchasing the ATLAS-18. All the lights have been checked and are in excellent operating condition. Please check the shipping carton first, because there may be damage occurred during the shipment. Then check the lights carefully and be sure that the lights is intact and works normally. In the event damage has been found, spare parts are missing or the lights works abnormally, please contact us for further instructions. And please don't return the lights to the dealer before contacting us.

Introduction: The ATLAS-18 has three operating modes: DMX mode, Auto mode and Master/Slave mode. And the lights has five DMX modes, including channel 3, channel 6, channel 8, channel 12 and channel 18. There are ten built-in Auto programs and you can see ten kinds of shows when you open the Auto mode. Meanwhile, you can edit your desired Auto program in "EDIT" menu. In addition, you can connect several pieces of lights in DMX mode and set one in Auto mode, and the others in Master/Slave mode. And then all the lights in Master/Slave mode will run following the one in Auto mode. Using fog or special effect smoke, you can see better showing effect.

Warning!

1. Don't expose the lights to rain or moisture, for the sake of preventing the risk of electrical shock or fire.
2. Don't look directly at the opening lights all the time, or it may damage your eyes.

UNPACKING AND PREPARATION

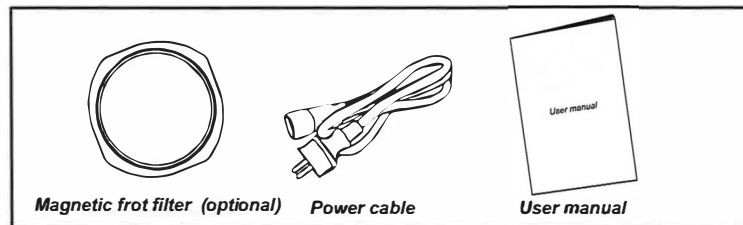

Product Overview

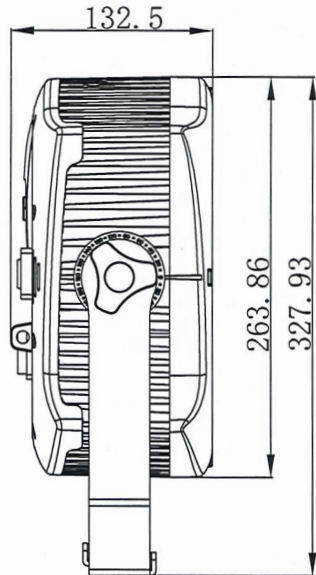
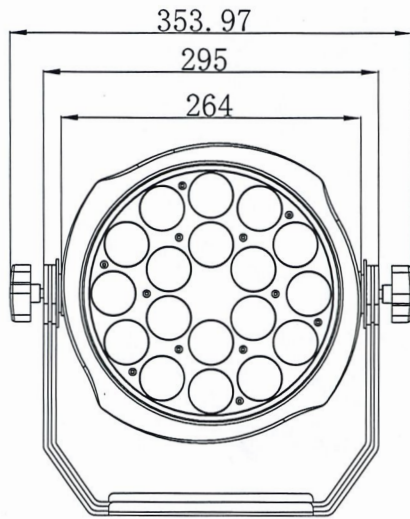

Features

- Light Source: 18*20W, 6 in 1 RGBWAUV LEDs
- Lens: 15°
- Power consumption: 330W
- Voltage: AC 90V -270V, 50/60Hz
- Run Mode: DMX 512 /Master Slave/Auto Run
- 10 internal programs and 11 customize programs
- 4 different dimming curve
- 11 kinds of color temperature white
- Maximum 66 ID setng for easy separate control
- DMX Channels: 3, 6, 8, 12 & 18CH
- Built-in Effect: color mixing, variable color chasing, strobing and fading.
- TFT displayer with four buttons
- Material: Aluminum body
- IP65
- Temperature: -30℃~45℃
- Dimension: 354 X 159 X 309 mm
- N.W: 8.5 KG
- G.W: 10 KG

Programme Menu

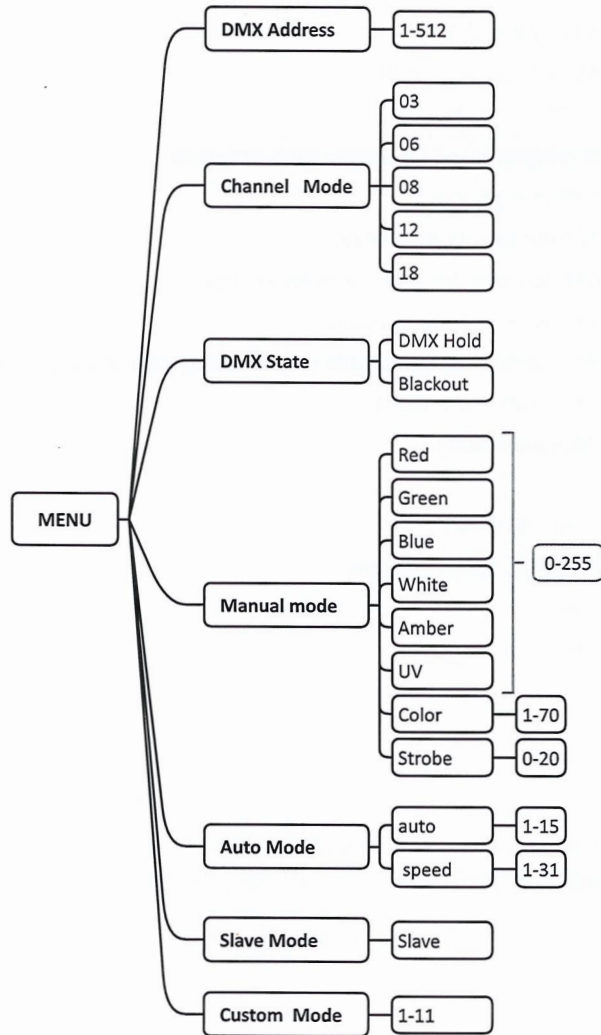

Mechanical Specification

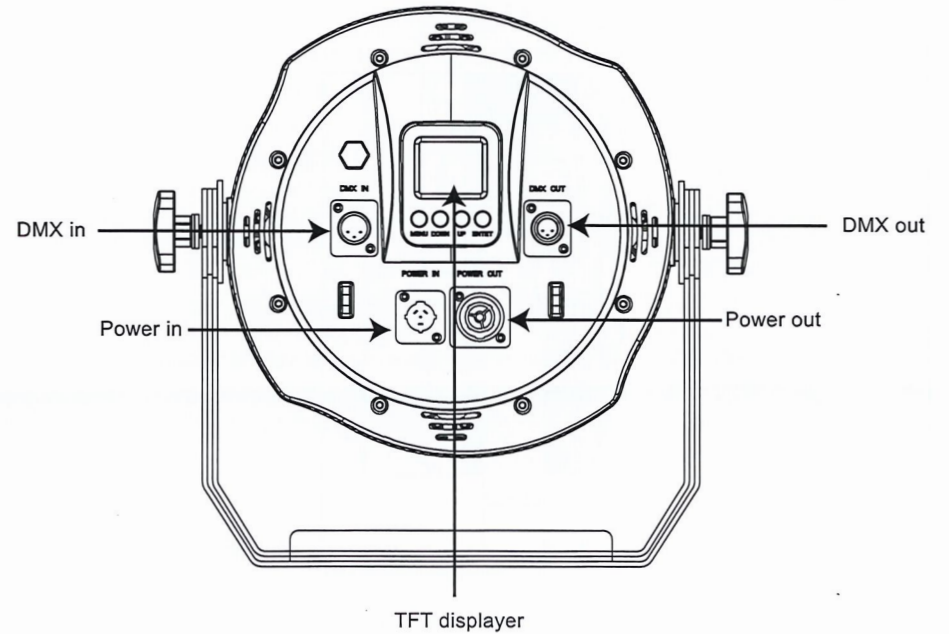
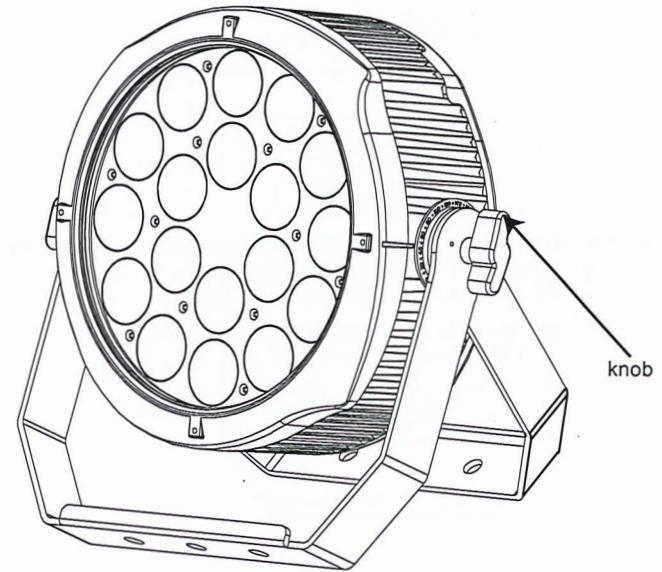

CABLE CONNECTORS

Cabling must have a male XLR connector on one end and a female XLR connector on the other end.

DMX connector configuration

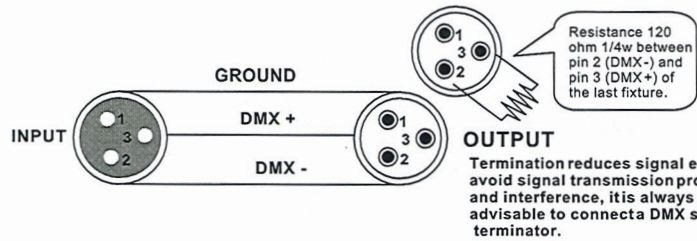

caution: Do not allow contact between the ground and the fixture's chassis ground. Grounding the ground can cause a ground loop, and your fixture may perform erratically. Test cables with an ohm meter to verify positive pole and to make sure the pins are not grounded or shorted to the shield or each other.

3-PIN TO 5-PIN CONVERSION CHART

Note! If you use a controller with a 5 pin DMX output connector, you need to use a 5 pin to 3 pin adapter. The chart below details a proper cable conversion:

Conductor	3 Pin Female (output)	5 Pin Male (Input)
Ground/Shield	Pin 1	Pin 1
Data (-) signal	Pin 2	Pin 2
Data (+) signal	Pin 3	Pin 3
Do not use		Do not use
Do not use		Do not use

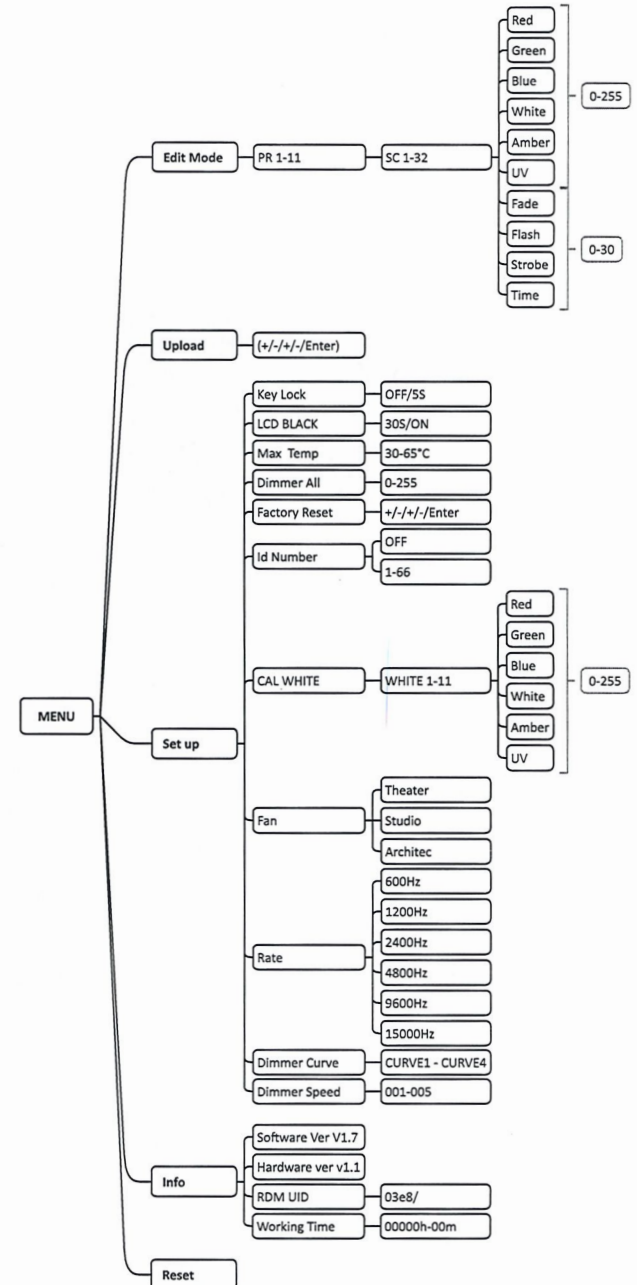

Displayer introduction

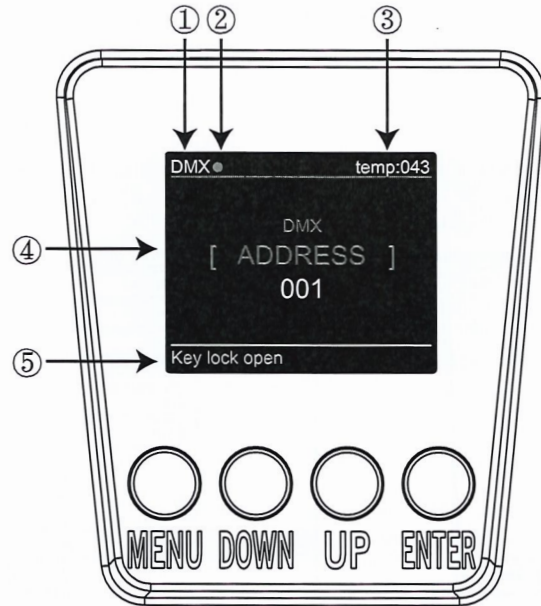

1. DMX means the light is in the DMX mode. Similarly, SLAVE means the light is in the SLAVE mode.
2. The color of the point shows the condition of signal transmission. Green represents the good condition, while red represents the signal is interrupted.
3. The item shows the working temperature of the light. When the working temperature exceeds the max temperature, the color of the letters and number will change from white to yellow.
4. This item shows the menu you selected.
5. This item shows the condition of key lock. "Key lock open" means the key lock is open. And "Key lock off" means the key lock is close.

Mounting

When installing the unit, the trussing or area of installation must be able to hold 10 times the weight without any deformation. When installing the unit must be secured with a secondary safety attachment, e.g. and appropriate safety cable. Never stand directly below the unit when mounting, removing, or servicing the unit.

Overhead mounting requires extensive experience, including calculating working load limits, installation material being used, and periodic safety inspection of all installation material and unit. If you lack these qualifications, do not attempt the installation yourself.

The installation should be checked by a skilled person once a year.

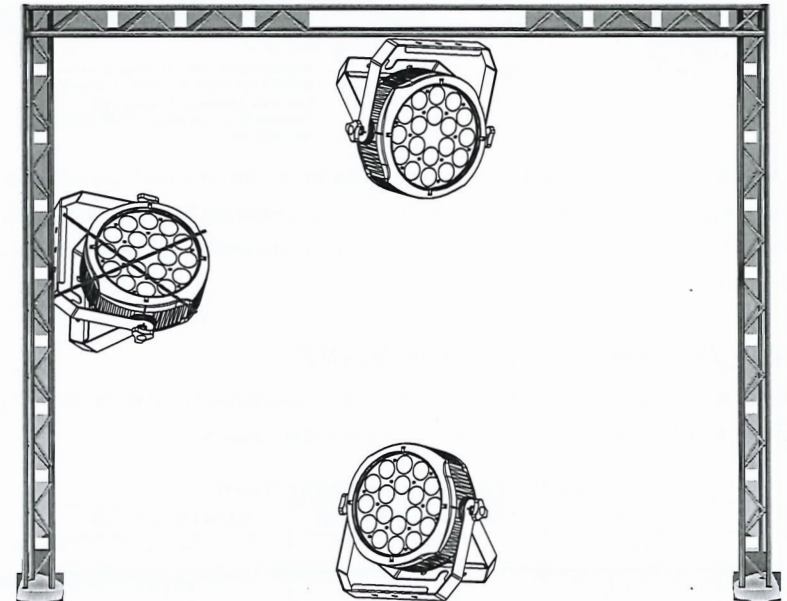

The ATLAS-18 is fully operational in two different mounting positions, hanging upside-down from a ceiling or set on a flat level surface. To avoid internal damage to the unit, never mount the unit on its side as illustrated above. Be sure this fixture is kept at least 0.5m away from any flammable materials (decoration etc.). And you'd better use and install the supplied safety cable as a safety measure to prevent accidental damage and/or injury in the event the clamp fails (see next page).

UPLOAD

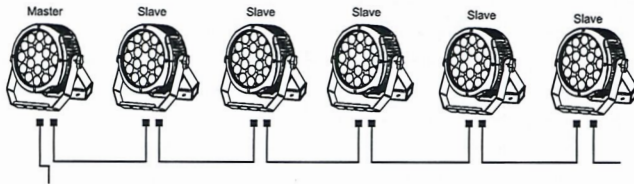

First, set one light, which involves the program you have edited in EDIT menu and want to upload, in Master mode, and others in Slave mode.

Then, connect all the lights with DMX cables. Finally, select the UPLOAD menu of the Master light and press ENTER. All the programs edited in the Master light will be uploaded to the Slave lights.

DMX Address-In this menu, you can select the DMX Address.

1. Press "ENTER" button and then UP or DOWN button until "DMX Address" is showed.
2. Press "ENTER" button, and "DMX Address" will be showed. Then press ENTER.
 - 1) "xxx" will be showed, "xxx" represents the showed address. You can press the UP or DOWN button to select your desired address.

Channels Mode-In this menu, you can connect several pieces of lights with DMX cable and control them with control console.

1. Press "ENTER" button and then UP or DOWN button until "Channels Mode" is showed.
2. Press "ENTER" button, and "Channels Mode" will be showed. Then press ENTER.
 - 1) "Channel [xx]" will be showed, "X" represents the showed DMX channel mode. You can press the UP or DOWN button to select your desired Channel mode.

DMX State-In this menu, you can learn about the information of DMX Hold and Blackout.

1. Press "ENTER" button and then UP or DOWN button until "DMX State" is showed.
2. Press "ENTER" button, and "DMX Hold" or "Blackout" will be showed. Then press ENTER, and you can select your desired mode.

Manual Mode-In this menu, you can adjust the value of static color and strobe speed as you like.

1. Press "ENTER" button and then UP or DOWN button until "Manual Mode" is showed.
2. Press "ENTER" button, and there are six options. Then press ENTER to select the option and press UP or DOWN button to select the value you desire as below:
 - 1) RED - You can adjust the red brightness in this menu.
 - 2) GREEN - You can adjust the green brightness in this menu.
 - 3) BLUE - You can adjust the blue brightness in this menu.
 - 4) WHITE - You can adjust the white brightness in this menu.
 - 5) COLOR - You can select 255 static color in this menu.
 - 6) STROB - You can adjust the strobe speed in this menu.

AUTO mode-In this menu, you can select your desire AUTO mode and adjust the running speed.

1. Press "ENTER" button and then UP or DOWN button until "AUTO mode" is showed.
2. Press "ENTER" button, and "SPEED" or "AUTO MODE" will be showed. Then press ENTER, and you can see two items as below:
 - 1) SPEED - You can select your desired speed in this menu.
 - 2) AUTO MODE - You can select your desired auto mode in this menu.

Slave Mode-In this menu, you can select SLAVE mode. In SLAVE mode, you can select one light as the MASTER light and other lights in SLAVE mode will run following the MASTER light.

1. Press "ENTER" button and then UP or DOWN button until "Slave MODE" is showed.
2. Press "ENTER" button, and "SLAVE" will be showed, then press ENTER to confirm.

CUSTOMER Mode-In this menu, you can select the AUTO program edited in the "EDIT" menu.

1. Press "ENTER" button and then UP or DOWN button until "CUSTOMER" is showed.
2. Press "ENTER" button, and there are 11 pre-programmed mode edited in the "EDIT" menu.

EDIT Mode-In this menu, you can edit your desired AUTO program.

1. Press "ENTER" button and then UP or DOWN button until "EDIT" is showed.

2. Press "ENTER" button, and open the "EDIT" mode to edit the custom programs from "PR.01" to "PR.11". And there are 32 scenes that can be edited in each custom program.
3. You can edit a scene by adjusting the value of "RED (0~255)", "GREEN (0~255)", "BLUE (0~255)", "WHITE (0~255)", "FADE (0~30)", "FLASH (0~30)", "STROBE (0~30)" & "TIME (0~30)" as you like. Then the data will be saved, when you press the ENTER button for 5 seconds.

UPLOAD-In this menu, you can connect several pieces of lights with MAX cables and set one light as the MASTER and others in SLAVE mode. Then upload the custom program in the MASTER light to the lights in SLAVE mode.

1. Press "ENTER" button and then UP or DOWN button until "UPLOAD" is showed.
2. Press "ENTER" button to upload the custom programs from the MASTER light to the SLAVE ones. The password is [UP] + [DOWN] + [UP] + [DOWN].

SET UP-In this menu, you can adjust the value of the function.

1. Press "ENTER" button and then UP or DOWN button until "SET UP" is showed.
2. Press "ENTER" button, and there will be nine options. Then, press ENTER to select the option and press UP or DOWN button to select the value you desire as below.
 - 1) ID number - You can select an ID Number in this menu. Then, you can adjust the value of channel 11 to the corresponding scope and control the light individually with control console.
 - 2) CAL WHITE- You can select the value of 11 different white color. And there are 11 pre-programmed White colors that can be edited by adjusting the value of "Red", "Green", "Blue", "White".
 - 3) LCD BLACK - In this item, you can select "ON" or "30S". If you select "ON", the displayer will be on all the time. And if you select "30S", the displayer will extinguish about ten seconds later.
 - 4) Key locks - You can select whether the password is ON or 30S in this menu, and the password is [UP] + [DOWN] + [UP] + [DOWN]. If you select "ON", then you have to input the password before pressing the buttons. Otherwise, the light won't respond to your order.
 - 5) Max temp - You can set the your desired Max working temperature about the light in this menu. When the working temperature of the light exceeds the Max temperature, the color of letter "Temp xx°C" showed in the menu will change from white to yellow. Meanwhile, the light will adjust the working temperature automatically.
 - 6) Dimmer ALL - You can adjust the brightness of each color in this menu.
 - 7) Factory Reset - You can reset the light.

INFORMATION-In this menu, you can learn about the information of software, hardware and the working time of the light.

1. Press "ENTER" button and then UP or DOWN button until "INFORMATION" is showed.
2. Press "ENTER" button, and "Software" "Hardware" or "Fix times" will be showed. Then press ENTER, and you can see three items as below:
 - 1) Software - This item displays the Software information.
 - 2) Hardware - This item displays the Hardware information.
 - 3) Fix times - This item displays the working hours about the light.

RESET-In this menu, you can reset all the value of the system.

1. Press "ENTER" button and then UP or DOWN button until "RESET" is showed.
2. Press the ENTER button to reset all the value of the system.

Channel 12 (Id address set)

0-9	all Ids	170-179	Id17	223	Id34	240	Id51
10-19	Id1	180-189	Id18	224	Id35	241	Id52
20-29	Id2	190-199	Id19	225	Id36	242	Id53
30-39	Id3	200-209	Id20	226	Id37	243	Id54
40-49	Id4	210	Id21	227	Id38	244	Id55
50-59	Id5	211	Id22	228	Id39	245	Id56
60-69	Id6	212	Id23	229	Id40	246	Id57
70-79	Id7	213	Id24	230	Id41	247	Id58
80-89	Id8	214	Id25	231	Id42	248	Id59
90-99	Id9	215	Id26	232	Id43	249	Id60
100-109	Id10	216	Id27	233	Id44	250	Id61
110-119	Id11	217	Id28	234	Id45	251	Id62
120-129	Id12	218	Id29	235	Id46	252	Id63
130-139	Id13	219	Id30	236	Id47	253	Id64
140-149	Id14	220	Id31	237	Id48	254	Id65
150-159	Id15	221	Id32	238	Id49	255	Id66
160-169	Id16	222	Id33	239	Id50		

DMX-512 addressing with ID address

1. Follow instructions 1 for DMX 512 addressing.
2. Activate ID addressing in each fixture by setting panel function "ID ON/OFF" to ON. "Settings" to "ID ON/OFF" to "ON" For every DMX 512 starting address the user can set 66 separate ID addresses. Set ID addresses in each fixture by setting panel function " ID address" to incremental values.(I.e. 1, 12, 24, 36 etc...) "Settings" to "address" to "01~66".

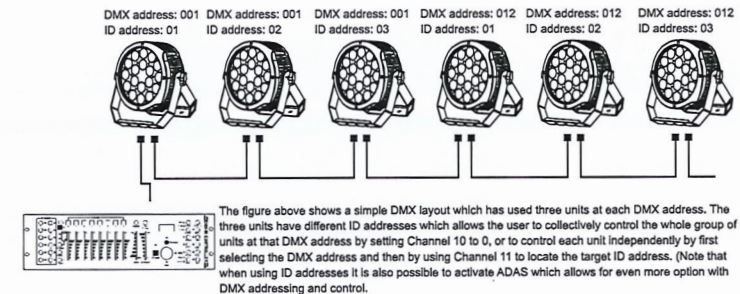

10	138 - 147	custom 4
	148 - 157	custom 5
	158 - 167	custom 6
	168 - 177	custom 7
	178 - 187	custom 8
	188 - 197	custom 9
	198 - 207	custom 10
	208 - 255	custom 11
11	000 - 255	Auto Speed
12	id	id address

18CH		
channel	value	function
1	000 - 255	Dimmer
2	000 - 255	dimmer 16 bit
3	000 - 255	Strobe from slow to fast
4	000 - 255	Red
5	000 - 255	Red 16 bit
6	000 - 255	Green
7	000 - 255	Green 16 bit
8	000 - 255	Blue
9	000 - 255	Blue 16 bit
10	000 - 255	White
11	000 - 255	White 16 bit
12	000 - 255	Amber
13	000 - 255	Amber 16 bit
14	000 - 255	UV
15	000 - 255	UV 16 bit
16	000 - 255	auto
17	000 - 255	auto Speed
18	000 - 255	id address

DMX control mode

3ch		
channel	value	function
1	000 - 255	Hue
2	000 - 255	Saturation
3	000 - 255	Dimmer

6 CH		
channel	value	function
1	000 - 255	Red
2	000 - 255	Green
3	000 - 255	Blue
4	000 - 255	White
5	000 - 255	Amber
6	000 - 255	UV

8 CH		
channel	value	function
1	000 - 255	Dimmer
2	000 - 255	Strobe from slow to fast
3	000 - 255	Red
4	000 - 255	Green
5	000 - 255	Blue
6	000 - 255	White
7	000 - 255	Amber
8	000 - 255	UV

12CH		
channel	value	function
1	000 - 255	Dimmer
2	000 - 255	Strobe from slow to fast
3	000 - 255	Red
4	000 - 255	Green
5	000 - 255	Blue
6	000 - 255	White
7	000 - 255	Amber
8	000 - 255	UV
9	000 - 010	No function
	011 - 012	Color 1
	013 - 016	Color 2
	017 - 023	Color 3
	024 - 027	Color 4
	028 - 031	Color 5
	032 - 035	Color 6
	036 - 039	Color 7
	040 - 043	Color 8
	044 - 047	Color 9
	048 - 051	Color 10
	052 - 055	Color 11
	056 - 059	Color 12
	060 - 063	Color 13
	064 - 067	Color 14
	068 - 071	Color 15
	072 - 083	Color 16
	084 - 087	Color 17
	088 - 091	Color 18
	092 - 095	Color 19
	096 - 099	Color 20
	100 - 103	Color 21
	104 - 107	Color 22
	108 - 111	Color 23
	112 - 115	Color 24
	116 - 123	Color 25
	124 - 127	Color 26
128 - 131	Color 27	

9	132 - 135	Color 28
	136 - 139	Color 29
	140 - 143	Color 30
	144 - 147	Color 31
	148 - 151	Color 32
	152 - 155	Color 33
	156 - 159	Color 34
	160 - 163	Color 35
	164 - 167	Color 36
	168 - 171	Color 37
	172 - 175	Color 38
	176 - 179	Color 39
	180 - 183	Color 40
	184 - 187	Color 41
	188 - 191	Color 42
	192 - 195	Color 43
	196 - 199	Color 44
	200 - 203	Color 45
	204 - 207	Color 46
	208 - 211	Color 47
	212 - 215	Color 48
216 - 219	Color 49	
220 - 222	Color 50	
233 - 255	Color 51	
10	000 - 007	No function
	008 - 017	auto 1
	018 - 027	auto 2
	028 - 037	auto 3
	038 - 047	auto 4
	048 - 057	auto 5
	058 - 067	auto 6
	068 - 077	auto 7
	078 - 087	auto 8
	088 - 097	auto 9
	098 - 107	auto 10
	108 - 117	custom 1
	118 - 127	custom 2
	128 - 137	custom 3