

# *User manual*

---

## **SLAN** **ATLAS-I2**

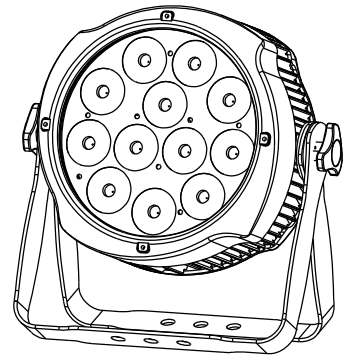

Please read carefully before use

---

Please Note: Specifications and improvements in the design of this unit and this manual are subject to change without any prior written notice.

**Packaging:** Thanks for your purchasing the ATLAS-12. All the lights have been checked and are in excellent operating condition. Please check the shipping carton first, because there may be damage occurred during the shipment. Then check the lights carefully and be sure that the lights is intact and works normally. In the event damage has been found, spare parts are missing or the lights works abnormally, please contact us for further instructions. And please don't return the lights to the dealer before contacting us.

**Introduction:** The ATLAS-12 has three operating modes: DMX mode, Auto mode and Master/Slave mode. And the lights has five DMX modes, including channel 3, channel 6, channel 8, channel 10 and channel 13. There are ten built-in Auto programs and you can see ten kinds of shows when you open the Auto mode. Meanwhile, you can edit your desired Auto program in "EDIT" menu. In addition, you can connect several pieces of lights in DMX mode and set one in Auto mode, and the others in Master/Slave mode. And then all the lights in Master/Slave mode will run following the one in Auto mode. Using fog or special effect smoke, you can see better showing effect.

**Warning!**

1. Don't expose the lights to rain or moisture, for the sake of preventing the risk of electrical shock or fire.
2. Don't look directly at the opening lights all the time, or it may damage your eyes.

**UNPACKING AND PREPARATION**

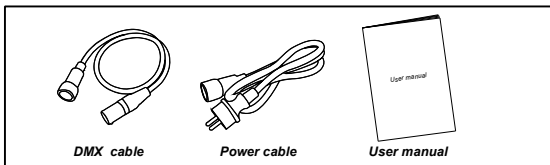

**Product Overview**

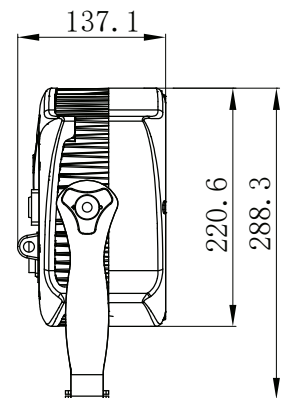
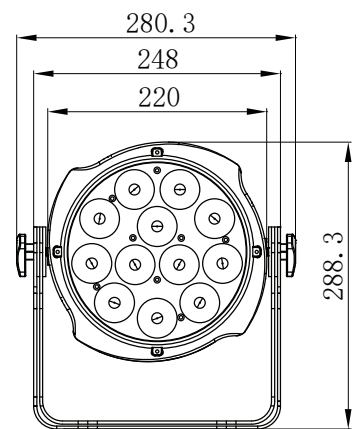

## Mechanical Specification

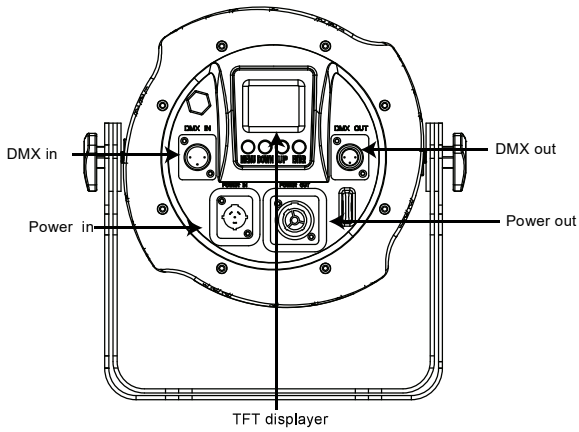
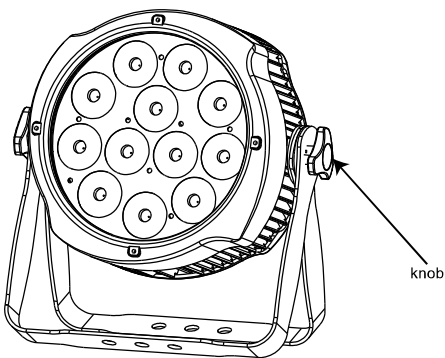

## Features

- Light Source: 12\*20W, 6 in 1 RGBWAUV LEDs
- Lens: 15°
- Power consumption: 150W
- Voltage: AC 100V -240V, 50/60Hz
- Run Mode: DMX 512 /Master Slave/Auto Run
- 10 internal programs and 11 customize programs
- 4 different dimming curve
- 11 kinds of color temperature white
- Maximum 66 ID setng for easy separate control
- DMX Channels: 3, 6, 8, 10 & 13CH
- Built-in Effect: color mixing, variable color chasing, strobing and fading.
- TFT displayer with four buttons
- Material: Aluminum body
- IP65
- Temperature: -30°C~45°C
- Dimension: 280.32 X 142.56 X 288.28 mm
- N.W: 5 KG
- G.W: 6 KG

## Programme Menu

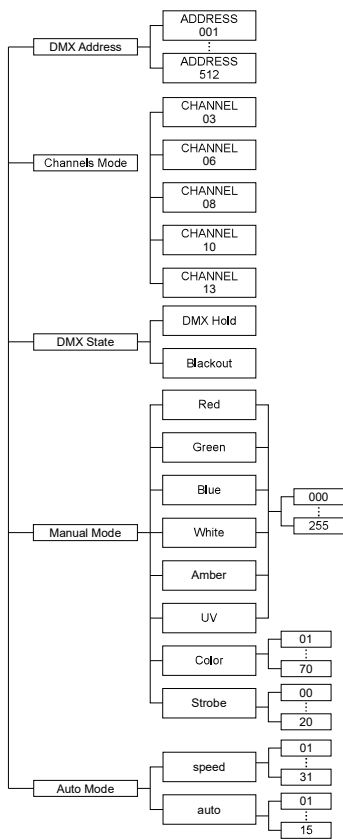

## CABLE CONNECTORS

Cabling must have a male XLR connector on one end and a female XLR connector on the other end.

### DMX connector configuration

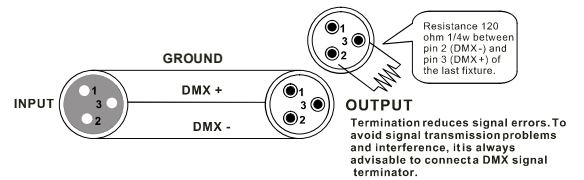

caution: Do not allow contact between the ground and the fixture's chassis ground. Grounding the ground can cause a ground loop, and your fixture may perform erratically. Test cables with an ohm meter to verify positive pole and to make sure the pins are not grounded or shorted to the shield or each other.

### 3-PIN TO 5-PIN CONVERSION CHART

Note! If you use a controller with a 5 pin DMX output connector, you need to use a 5 pin to 3 pin adapter. The chart below details a proper cable conversion:

3-PIN TO 5-PIN CONVERSION CHART		
Conductor	3 Pin Female (output)	5 Pin Male (Input)
Ground/Shield	Pin 1	Pin 1
Data ( - ) signal	Pin 2	Pin 2
Data ( + ) signal	Pin 3	Pin 3
Do not use		Do not use
Do not use		Do not use

## Mounting

When installing the unit, the trussing or area of installation must be able to hold 10 times the weight without any deformation. When installing the unit must be secured with a secondary safety attachment, e.g. and appropriate safety cable. Never stand directly below the unit when mounting, removing, or servicing the unit.

Overhead mounting requires extensive experience, including calculating working load limits, installation material being used, and periodic safety inspection of all installation material and unit. If you lack these qualifications, do not attempt the installation yourself.

The installation should be checked by a skilled person once a year.

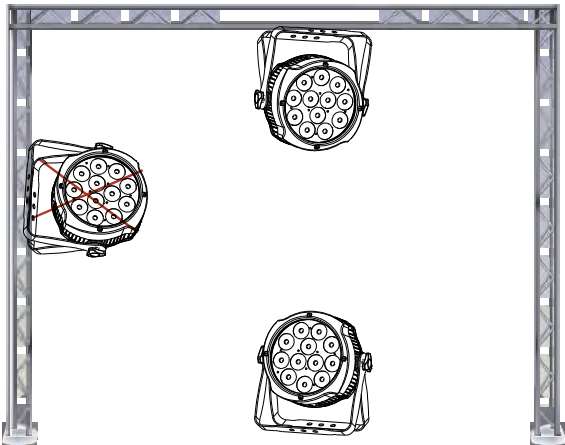

The ATLAS-12 is fully operational in two different mounting positions, hanging upside-down from a ceiling or set on a flat level surface. To avoid internal damage to the unit, never mount the unit on its side as illustrated above. Be sure this fixture is kept at least 0.5m away from any flammable materials (decoration etc.). And you'd better use and install the supplied safety cable as a safety measure to prevent accidental damage and/or injury in the event the clamp fails (see next page).

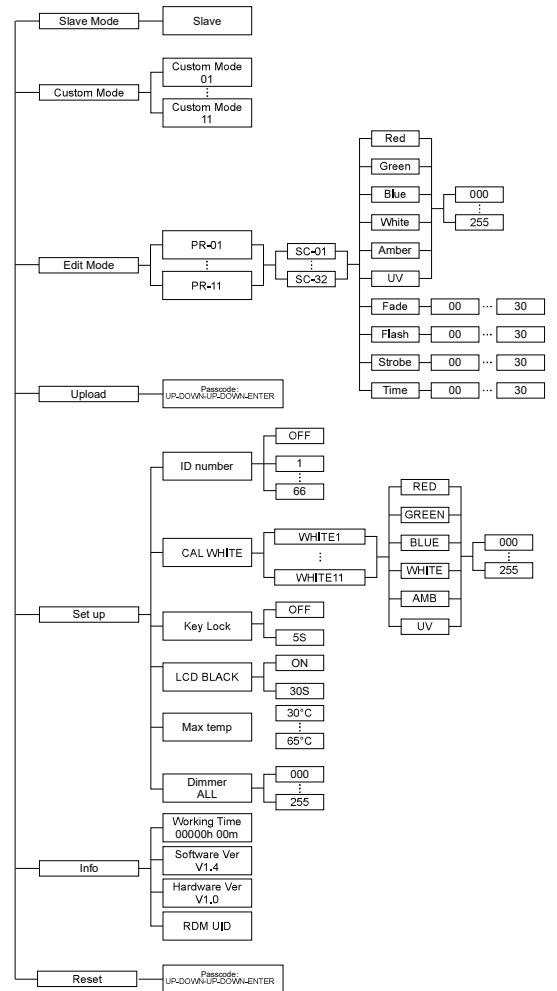

## Displayer introduction

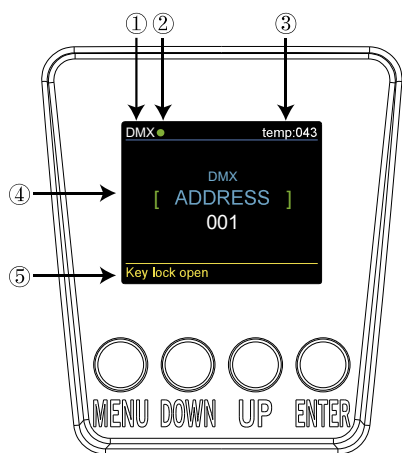

1. DMX means the light is in the DMX mode. Similarly, SLAVE means the light is in the SLAVE mode.
2. The color of the point shows the condition of signal transmission. Green represents the good condition, while red represents the signal is interrupted.
3. The item shows the working temperature of the light. When the working temperature exceeds the max temperature, the color of the letters and number will change from white to yellow.
4. This item shows the menu you selected.
5. This item shows the condition of key lock. "Key lock open" means the key lock is open. And "Key lock off" means the key lock is close.

## UPLOAD

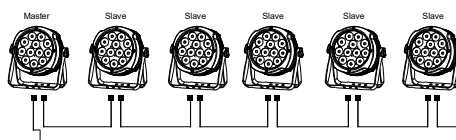

First, set one light, which involves the program you have edited in EDIT menu and want to upload, in Master mode, and others in Slave mode.

Then, connect all the lights with DMX cables. Finally, select the UPLOAD menu of the Master light and press ENTER. All the programs edited in the Master light will be uploaded to the Slave lights.

**Channel 13 (Id address set)**

0-9	all Ids	170-179	Id17	223	Id34	240	Id51
10-19	Id1	180-189	Id18	224	Id35	241	Id52
20-29	Id2	190-199	Id19	225	Id36	242	Id53
30-39	Id3	200-209	Id20	226	Id37	243	Id54
40-49	Id4	210	Id21	227	Id38	244	Id55
50-59	Id5	211	Id22	228	Id39	245	Id56
60-69	Id6	212	Id23	229	Id40	246	Id57
70-79	Id7	213	Id24	230	Id41	247	Id58
80-89	Id8	214	Id25	231	Id42	248	Id59
90-99	Id9	215	Id26	232	Id43	249	Id60
100-109	Id10	216	Id27	233	Id44	250	Id61
110-119	Id11	217	Id28	234	Id45	251	Id62
120-129	Id12	218	Id29	235	Id46	252	Id63
130-139	Id13	219	Id30	236	Id47	253	Id64
140-149	Id14	220	Id31	237	Id48	254	Id65
150-159	Id15	221	Id32	238	Id49	255	Id66
160-169	Id16	222	Id33	239	Id50		

**DMX-512 addressing with ID address**

- Follow instructions 1 for DMX 512 addressing.
- Activate ID addressing in each fixture by setting panel function "ID ON/OFF" to ON. "Settings" to "ID ON/OFF" to "ON" For every DMX 512 starting address the user can set 66 separate ID addresses. Set ID addresses in each fixture by setting panel function " ID address" to incremental values.(I.e. 1, 12, 24, 36 etc...) "Settings" to "address" to "01~66".

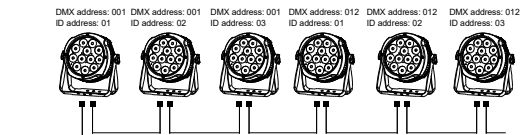

The figure above shows a simple DMX layout which has used three units at each DMX address. The three units have different ID addresses which allows the user to collectively control the whole group of units at that DMX address by setting Channel 10 to 0, or to control each unit independently by first selecting the DMX address and then by using Channel 11 to locate the target ID address. (Note that when using ID addresses it is also possible to activate ADAS which allows for even more option with DMX addressing and control.

DMX Address-In this menu, you can select the DMX Address.

- Press "ENTER" button and then UP or DOWN button until "DMX Address " is showed.
- Press "ENTER" button, and "DMX Address" will be showed. Then press ENTER.
  - "xxx" will be showed, "xxx" represents the showed address. You can press the UP or DOWN button to select your desired address.

Channels Mode-In this menu, you can connect several pieces of lights with DMX cable and control them with control console.

- Press "ENTER" button and then UP or DOWN button until "Channels Mode " is showed.
- Press "ENTER" button, and "Channels Mode" will be showed. Then press ENTER.
  - "Channel [xx]" will be showed, "X" represents the showed DMX channel mode. You can press the UP or DOWN button to select your desired Channel mode.

DMX State-In this menu, you can learn about the information of DMX Hold and Blackout.

- Press "ENTER" button and then UP or DOWN button until "DMX State" is showed.
- Press "ENTER" button, and "DMX Hold" or "Blackout" will be showed. Then press ENTER, and you can select your desired mode.

Manual Mode-In this menu, you can adjust the value of static color and strobe speed as you like.

- Press "ENTER" button and then UP or DOWN button until "Manual Mode" is showed.
- Press "ENTER" button, and there are six options. Then press ENTER to select the option and press UP or DOWN button to select the value you desire as below:
  - RED - You can adjust the red brightness in this menu.
  - GREEN - You can adjust the green brightness in this menu.
  - BLUE - You can adjust the blue brightness in this menu.
  - WHITE - You can adjust the white brightness in this menu.
  - AMB - You can adjust the amber brightness in this menu.
  - UV - You can adjust the purple brightness in this menu.
  - COLOR -You can select 70 static color in this menu.
  - STROB - You can adjust the strobe speed in this menu.

AUTO mode-In this menu, you can select your desire AUTO mode and adjust the running speed.

- Press "ENTER" button and then UP or DOWN button until "AUTO mode" is showed.
- Press "ENTER" button, and "SPEED" or "AUTO MODE" will be showed. Then press ENTER, and you can see two items as below:
  - SPEED - You can select your desired speed in this menu.
  - AUTO MODE - You can select your desired auto mode in this menu.

Slave Mode-In this menu, you can select SLAVE mode. In SLAVE mode, you can select one light as the MASTER light and other lights in SLAVE mode will run following the MASTER light.

- Press "ENTER" button and then UP or DOWN button until "Slave MODE" is showed.
- Press "ENTER" button, and "SLAVE" will be showed, then press ENTER to confirm.

CUSTOMER Mode-In this menu, you can select the AUTO program edited in the "EDIT" menu.

- Press "ENTER" button and then UP or DOWN button until "CUSTOMER" is showed.
- Press "ENTER" button, and there are 11 pre-programmed mode edited in the "EDIT" menu.

**EDIT Mode**-In this menu, you can edit your desired AUTO program.

1. Press "ENTER" button and then UP or DOWN button until "EDIT" is showed.
2. Press "ENTER" button, and open the "EDIT" mode to edit the custom programs from "PR.01" to "PR.11". And there are 32 scenes that can be edited in each custom program.
3. You can edit a scene by adjusting the value of "RED (0~255)", "GREEN (0~255)", "BLUE (0~255)", "WHITE (0~255)", "AMBER (0~255)", "PURPLE (0~255)", "FADE (0~30)", "FLASH(0~30)", "STROBE (0~30)" & "TIME (0~30)" as you like. Then the data will be saved, when you press the ENTER button for 5 seconds.

**UPLOAD**-In this menu, you can connect several pieces of lights with MAX cables and set one light as the MASTER and others in SLAVE mode. Then upload the custom program in the MASTER light to the lights in SLAVE mode.

1. Press "ENTER" button and then UP or DOWN button until "UPLOAD" is showed.
2. Press "ENTER" button to upload the custom programs from the MASTER light to the SLAVE ones. The password is [UP ] + [DOWN ] + [ UP ] + [DOWN ].

**SET UP**-In this menu, you can adjust the value of the function.

1. Press "ENTER" button and then UP or DOWN button until "SET UP" is showed.
2. Press "ENTER" button, and there will be nine options. Then, press ENTER to select the option and press UP or DOWN button to select the value you desire as below.
  - 1) ID number - You can select an ID Number in this menu. Then, you can adjust the value of channel 11 to the corresponding scope and control the light individually with control console.
  - 2) CAL WHITE- You can select the value of 11 different white color. And there are 11 pre-programmed White colors that can be edited by adjusting the value of "Red", "Green", "Blue", "White", "Amb" and "UV".
  - 3) LCD BLACK - In this item, you can select "ON" or "30S". If you select "ON", the display will be on all the time. And if you select "30S", the display will extinguish about ten seconds later.
  - 4) Key locks - You can select whether the password is ON or 30S in this menu, and the password is [UP ] + [DOWN ] + [UP ] + [DOWN ]. If you select "ON", then you have to input the password before pressing the buttons. Otherwise, the light won't respond to your order.
  - 5) Max temp - You can set the your desired Max working temperature about the light in this menu. When the working temperature of the light exceeds the Max temperature, the color of letter "Temp xx°C" showed in the menu will change from white to yellow. Meanwhile, the light will adjust the working temperature automatically.
  - 6) Dimmer ALL - You can adjust the brightness of each color in this menu.
  - 7) Factory Reset - You can reset the light.

**INFORMATION**-In this menu, you can learn about the information of software, hardware and the working time of the light.

1. Press "ENTER" button and then UP or DOWN button until "INFORMATION" is showed.
2. Press "ENTER" button, and "Software" "Hardware" or "Fix times" will be showed. Then press ENTER, and you can see three items as below:
  - 1) Software - This item displays the Software information.
  - 2) Hardware - This item displays the Hardware information.
  - 3) Fix times - This item displays the working hours about the light.

**RESET**-In this menu, you can reset all the value of the system.

1. Press "ENTER" button and then UP or DOWN button until "RESET" is showed.
2. Press the ENTER button to reset all the value of the system.

9	0 - 9	Default
	10 - 255	strobe (0Hz - 20Hz)
10	0 - 7	Default
	8 - 17	Auto 1
	18 - 37	Auto 2
	38 - 57	Auto 3
	58 - 77	Auto 4
	78 - 87	Auto 5
	88 - 97	Auto 6
	98 - 107	Auto 7
	108 - 117	Custom1
	118 - 127	Custom2
	128 - 137	Custom3
	138 - 147	Custom4
	148 - 157	Custom5
	158 - 167	Custom6
	168 - 177	Custom7
	178 - 187	Custom8
	188 - 197	Custom9
	198 - 207	Custom10
208 - 255	Custom11	
11	0 - 255	Speed when auto is enable
	0 - 49	Off dimmer speed
12	50 - 99	Dimmer speed 1
	100 - 149	Dimmer speed 2
	150 - 199	Dimmer speed 3
	200 - 255	Dimmer speed 4

**DMX 13 channel**

channel	value	function
1	0 - 255	0 = Off 1 - 255 = Master dimmer
2	0 - 255	Adjust red LEDs Dimmer from low to high
3	0 - 255	Adjust green LEDs Dimmer from low to high
4	0 - 255	Adjust blue LEDs Dimmer from low to high
5	0 - 255	Adjust white LEDs Dimmer from low to high
6	0 - 255	Adjust Amber LEDs Dimmer from low to high
7	0 - 255	Adjust UV LEDs Dimmer from low to high
8	0 - 10	No function
	11 - 20	R100%/Gup/B0%/W0%
	21 - 30	Rdown/G100%/B0%/W0%
	31 - 40	R0%/G100%/Bup/W0%
	41 - 50	Rup/Gdown/B100%/W0%
	51 - 60	Rup/G0%/B100%/W0%
	61 - 70	R100%/G0%/Bdown/W0%
	71 - 80	R100%/G0%/B0%/Wup
	81 - 90	R100%/G0%/B0%/Wdown
	91 - 100	R↑/G↓/B0%/W0%→R↓/G↑/B0%/W0%
	101 - 110	R↑/G0%/B↓/W0%→R↓/G0%/B↑/W0%
	111 - 120	R0%/G↑/B↓/W0%→R0%/G↓/B↑/W0%
	121 - 130	R0%/G↑/B0%/W↓→R0%/G↓/B0%/W↑
	131 - 140	R↑/G↑/B↓/W0%→R↓/G↓/B↑/W0%
	141 - 150	R↑/G↓/B↓/W0%→R↓/G↑/B↑/W0%
	151 - 160	R↑/G↓/B↑/W0%→R↓/G↑/B↓/W0%
	161 - 170	R↑/G↑/B0%/W↓→R↓/G↓/B0%/W↑
	171 - 200	RGBW
	201 - 205	White 1
	206 - 210	White 2
	211 - 215	White 3
	216 - 220	White 4
	221 - 225	White 5
	226 - 230	White 6
	231 - 235	White 7
236 - 240	White 8	
241 - 245	White 9	
246 - 250	White 10	
251 - 255	White 11	

**DMX control mode**

**DMX 3 channel**

channel	value	function
1	0 - 255	Hue
2	0 - 255	Saturation
3	0 - 255	Value(brightness)

**DMX 6 channel**

channel	value	function
1	0 - 255	Adjust red LEDs Dimmer from low to high
2	0 - 255	Adjust green LEDs Dimmer from low to high
3	0 - 255	Adjust blue LEDs Dimmer from low to high
4	0 - 255	Adjust white LEDs Dimmer from low to high
5	0 - 255	Adjust Amber LEDs Dimmer from low to high
6	0 - 255	Adjust UV LEDs Dimmer from low to high

**DMX 8 channel**

channel	value	function
1	0 - 255	0 = Off 1 - 255 = Master dimmer
2	0 - 255	Adjust red LEDs Dimmer from low to high
3	0 - 255	Adjust green LEDs Dimmer from low to high
4	0 - 255	Adjust blue LEDs Dimmer from low to high
5	0 - 255	Adjust white LEDs Dimmer from low to high
6	0 - 255	Adjust Amber LEDs Dimmer from low to high
7	0 - 255	Adjust UV LEDs Dimmer from low to high
8	0 - 9	No function
	10 - 255	Strobe form slow to fast

**DMX 10 channel**

channel	value	function
1	0 - 255	0 = Off 1 - 255 = Master dimmer
2	0 - 255	Adjust red LEDs Dimmer from low to high
3	0 - 255	Adjust green LEDs Dimmer from low to high
4	0 - 255	Adjust blue LEDs Dimmer from low to high
5	0 - 255	Adjust white LEDs Dimmer from low to high
6	0 - 255	Adjust Amber LEDs Dimmer from low to high
7	0 - 255	Adjust UV LEDs Dimmer from low to high
8	0 - 23	none
	24 - 27	red
	28 - 31	green
	32 - 35	blue
	36 - 39	yellow
	40 - 43	cyan
	44 - 47	magenta
	48 - 51	white
	52 - 55	orange
	56 - 59	pink
	60 - 63	violet
	64 - 67	aquamarine
	68 - 71	sky blue
	72 - 75	full white
	76 - 79	cool white
	80 - 83	warm white
	84 - 87	white 3200
	88 - 91	white 2500
	92 - 95	yellow 2
	96 - 99	straw
	100 - 103	orange 2
	104 - 107	light rose
	108 - 111	dark pink
	112 - 115	magenta 2
	116 - 119	blue 2
	120 - 123	med blue green
	124 - 127	dark blue
	128 - 131	bright pink
	132 - 135	medium blue
	136 - 139	golden amber
	140 - 143	deep golden amber
	144 - 147	pale lavender
148 - 151	apricot	
152 - 155	dark lavender	

	156 - 159	chocolate	
	160 - 163	just blue	
	164 - 167	surprise pink	
	168 - 171	scarlet	
	172 - 175	surprise peach	
	176 - 179	fire	
	180 - 183	english rose	
	184 - 187	mauve	
	188 - 191	bright blue	
	192 - 195	alice blue	
	196 - 199	rose indigo	
	200 - 203	urban blue	
	204 - 207	cool blue	
	208 - 211	Light salmon	
	212 - 215	mayan sun	
	216 - 219	cherry rose	
	220 - 223	flesh pink	
	224 - 255	skelton exotic sangria	
	9	0 - 7	Default
		8 - 17	Auto 1
		18 - 37	Auto 2
		38 - 57	Auto 3
58 - 77		Auto 4	
78 - 87		Auto 5	
88 - 97		Auto 6	
98 - 107		Auto 7	
108 - 117		Custom1	
118 - 127		Custom2	
128 - 137		Custom3	
138 - 147		Custom4	
148 - 157		Custom5	
158 - 167		Custom6	
168 - 177		Custom7	
178 - 187		Custom8	
188 - 197		Custom9	
198 - 207	Custom10		
208 - 255	Custom11		
10	0 - 255	Auto Speed from slow to fast(Auto > 0)	
	0-9	No function	
	10-255	Strobe from slow to fast	