

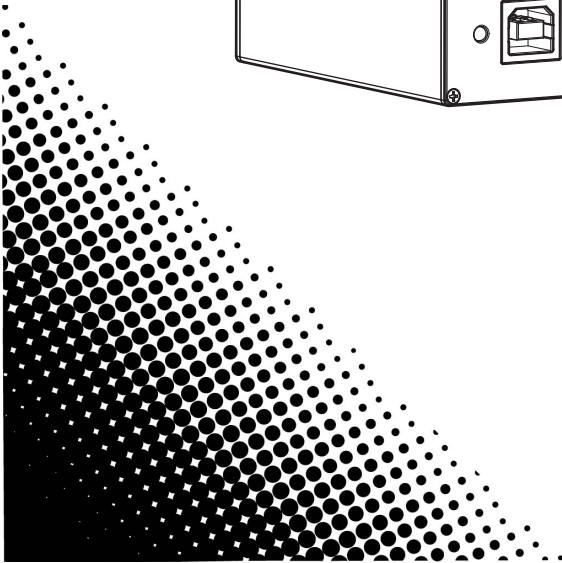

## User Manual

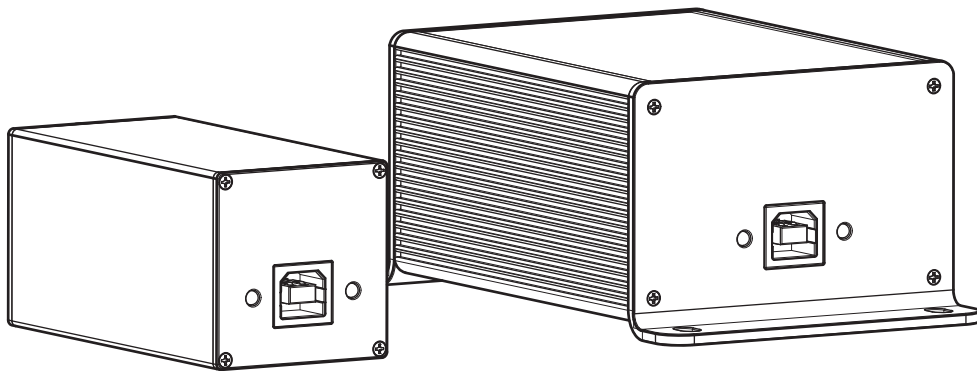

---

**TABLE OF CONTENTS**

<b>1. Before You Begin</b> .....	1
What Is Included .....	1
Unpacking Instructions .....	1
Claims .....	1
Text Conventions .....	1
Symbols .....	1
Disclaimer .....	1
Intellectual Property .....	1
Safety Notes.....	2
<b>2. Introduction</b> .....	3
Product Overview.....	3
Product Dimensions.....	3
<b>3. Setup</b> .....	4
DC Power.....	4
ShowXpress Software.....	4
Plug and Play.....	4
Minimum System Requirements .....	4
Mounting .....	4
<b>4. Operation</b> .....	5
LED Indicators.....	5
Troubleshooting .....	5
Standalone Playback .....	5
Timelines.....	5
Zones .....	5
Art-Net™ Universe Access .....	5
<b>5. Technical Specifications</b> .....	6
<b>Returns</b> .....	7
<b>Contact Us</b> .....	8

# 1. Before You Begin

## What Is Included

- XPRESS-512S / XPRESS-1024
- USB cable

## Unpacking Instructions

Carefully unpack the product immediately and check the container to make sure all the parts are in the package and are in good condition.

### Claims



If the box or the contents (the product and included accessories) appear damaged from shipping, or show signs of mishandling, notify the carrier immediately, not Chauvet. Failure to report damage to the carrier immediately may invalidate your claim. In addition, keep the box and contents for inspection.

For other issues, such as missing components or parts, damage not related to shipping, or concealed damage, file a claim with Chauvet within 7 days of delivery.

## Text Conventions

Convention	Meaning
<b>1–512</b>	A range of values
<b>50/60</b>	A set of values of which only one can be chosen
<b>Settings</b>	A menu option not to be modified
<b>&lt;ENTER&gt;</b>	A key to be pressed on the product’s control panel
<b>ON</b>	A value to be entered or selected

## Symbols

Symbol	Meaning
	Critical installation, configuration, or operation information. Not following these instructions may make the product not work, cause damage to the product, or cause harm to the operator.
	Important installation or configuration information. The product may not function correctly if this information is not used.
	Useful information.

## Disclaimer

Chauvet believes that the information contained in this manual is accurate in all respects. However, Chauvet assumes no responsibility and specifically disclaims any and all liability to any party for any loss, damage or disruption caused by any errors or omissions in this document, whether such errors or omissions result from negligence, accident or any other cause. Chauvet reserves the right to revise the content of this document without any obligation to notify any person or company of such revision, however, Chauvet has no obligation to make, and does not commit to make, any such revisions. Download the latest version from [www.chauvetdj.com](http://www.chauvetdj.com).

## Intellectual Property

The works of authorship contained in this manual, including, but not limited to, all design, text and images are owned by Chauvet.

© Copyright 2020 Chauvet & Sons, LLC. All rights reserved.

Electronically published by Chauvet in the United States of America.

CHAUVET, the Chauvet logo, and XPRESS-512S / XPRESS-1024 are registered trademarks or trademarks of Chauvet & Sons LLC (d/b/a Chauvet and Chauvet Lighting) in the United States and other countries. Other company and product names and logos referred to herein may be trademarks of their respective companies.

### Safety Notes



- This product is not intended for permanent installation.
- Always connect the product to a grounded circuit to avoid the risk of electrocution.
- Make sure the power (USB) cord is not crimped or damaged.
- Never disconnect the product from power by pulling or tugging on the cord.
- Make sure there are no flammable materials close to the product when operating.
- Do not touch the product's housing when operating because it may be very hot.



- The voltage of the outlet to which you are connecting this product must be within the range stated on the decal or rear panel of the product.
- The product is for indoor use only! (IP20) To prevent risk of fire or shock, do not expose the product to rain or moisture.
- Always install the product in a location with adequate ventilation, at least 20 in (50 cm) from adjacent surfaces.
- Be sure that no ventilation slots on the product's housing are blocked.
- Never connect the product to a dimmer or rheostat.
- Never carry the product from the power cord.
- The maximum ambient temperature is 104 °F (40 °C). Do not operate this product at higher temperatures.
- In the event of a serious operating problem, stop using the product immediately.
- Do not open this product. It contains no user-serviceable parts.
- To eliminate unnecessary wear and improve its lifespan, during periods of non-use completely disconnect the product from power via breaker or by unplugging it.



Keep this User Manual for future use. If the product is sold to someone else, be sure that they also receive this document.

## 2. Introduction

### Product Overview

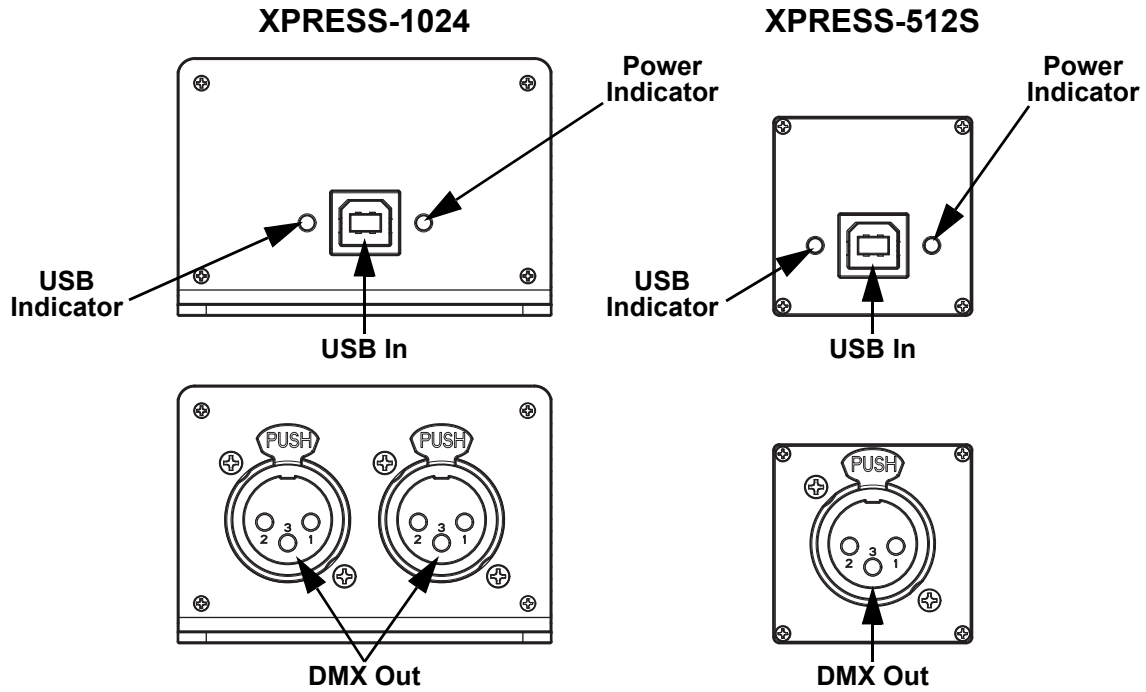

### Product Dimensions

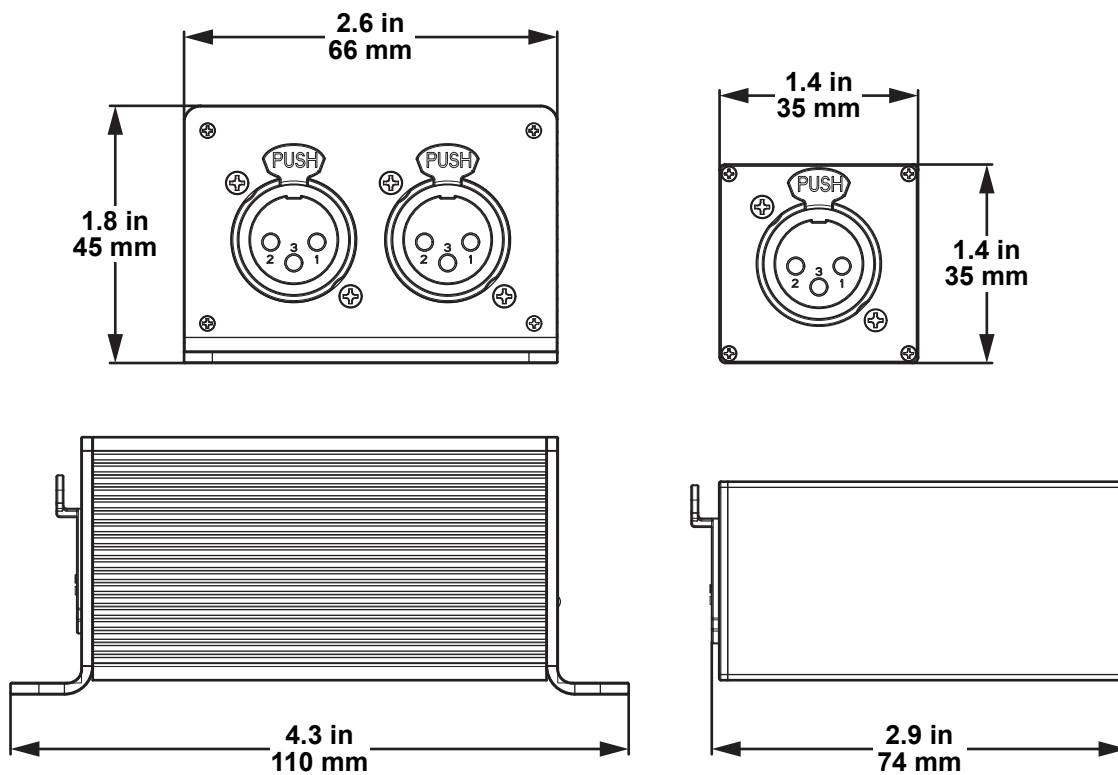

### 3. Setup

#### DC Power

The XPRESS-512S / XPRESS-1024 is a hot-swappable USB-to-DMX interface, designed to connect to and be powered by the USB port of a computer using Windows<sup>®</sup> 10 (no other versions supported) or Mac OS X. The required DC voltage is 5 V, which is standard across most computers.

#### ShowXpress Software

The XPRESS-512S / XPRESS-1024 requires a computer with the ShowXpress software installed to function until a [Standalone](#) program is uploaded. Download the ShowXpress software for free from [www.chauvetdj.com](http://www.chauvetdj.com).

#### Plug and Play

The XPRESS-512S / XPRESS-1024 drivers are included in the installation of the ShowXpress software. Once the software is installed, both products are hot-swappable, and will re-connect within seconds of being plugged in to the computer.

In the unlikely case that the product is not recognized, the drivers can be downloaded from [www.chauvetdj.com](http://www.chauvetdj.com) and manually installed.

#### Minimum System Requirements

- Windows<sup>®</sup> 10 - Core 2 duo (year 2005), 2 GB RAM
- Mac OS X - All Intel-based Mac computers with Leopard and more

#### Mounting

The XPRESS-512S should be placed on a flat, stable surface.

The XPRESS-1024 can either be placed on a flat, stable surface, or secured with zip-ties, screws, or anything else which fits through the mounting holes.

Before deciding on a location for either product, read the [Safety Notes](#).

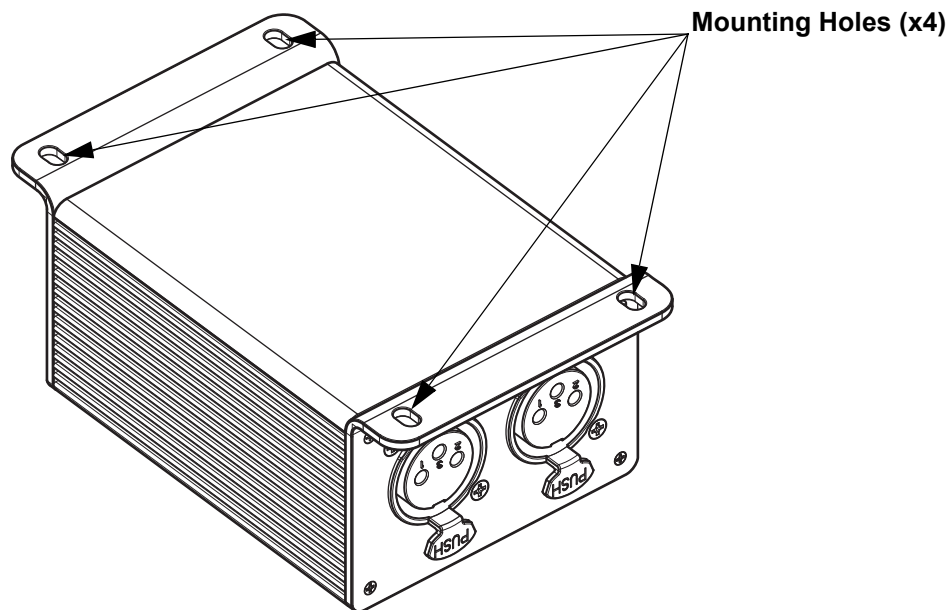

## 4. Operation

### LED Indicators

When plugged in, the two LED indicators display the status of the product.

The **PWR** indicator indicates that the product is receiving sufficient DC power.

The **USB** indicator indicates that the product is connected to, and receiving a signal from, the ShowXpress software.

### Troubleshooting

If the USB indicator is not flashing, try the following steps:

1. Close the ShowXpress software.
2. Disconnect the XPRESS-512S / XPRESS-1024 from the computer.
3. Wait 10 seconds.
4. Re-connect the XPRESS-512S / XPRESS-1024 to the computer.
5. Re-open the ShowXpress software.

If this does not work, try re-installing the device driver manually. The current device drivers are available on [www.chauvetdj.com](http://www.chauvetdj.com).

If re-installing the device driver does not work, call Chauvet Customer Service.

### Standalone Playback

The XPRESS-512S / XPRESS-1024 can store a DMX program to call back while not plugged into a computer. After programming the show to be uploaded, do the following:

1. Navigate to the **StandAlone** tab.
2. Add the desired scene or scenes to one or more [Timelines](#).
3. Assign the program to one of the [Zones](#) using the drop-down menu.
4. Click **Upload data**.



**The uploaded program will immediately begin when the product is connected to power.**

### Timelines

The **Timelines** allow for the placement and timing of multiple scenes in a **Zone**. Only one set of **Timelines** can be activated in each **Zone** at one time.

### Zones

4 zones are available for independent programming. Activating a program in one zone does not affect the programs running in the other zones, but does replace any program previously running in that zone. Zones may overlap with each other, but if affecting the same value as a program in another zone, the most recently activated value will take precedence.

### Art-Net™ Universe Access

The use of either product each unlocks an additional Art-Net™ universe through the ShowXpress software while it is plugged in. If used, these universes count towards the total maximum number of universes allowed by the software (6 universes).



**The use of Art-Net™ may require additional hardware.**

Art-Net™ Designed by and Copyright Artistic Licence Holdings Ltd.

## 5. Technical Specifications

### Dimensions and Weight

Product	Length	Width	Height	Weight
XPRESS-512S	2.9 in (74 mm)	1.4 in (35 mm)	1.4 in (35 mm)	0.2 lb (0.1 kg)
XPRESS-1024	4.3 in (110 mm)	2.6 in (66 mm)	1.8 in (45 mm)	0.4 lb (0.2 kg)

**Note:** Dimensions in inches are rounded.

### Power

Power Supply Type	Input Voltage
USB (external)	5 V DC (USB)

### Thermal

Maximum External Temperature	Cooling System
104 °F (40 °C)	Convection

### DMX

Product	Output Connector	Channel Range	Refresh Rate
XPRESS-512S	3-pin XLR	512 + 512 via Art-Net™	40 Hz
XPRESS-1024	3-pin XLR x2	1024 + 512 via Art-Net™	40 Hz

### Ordering

Product Name	Item Code	UPC Number
XPRESS-512S	11081585	781462219338
XPRESS-1024	11081584	781462219321



# Returns

In case you need to get support or return a product:

- If you are located in the U.S., contact Chauvet World Headquarters.
- If you are located in the UK or Ireland, contact Chauvet Europe Ltd.
- If you are located in Benelux, contact Chauvet Europe BVBA.
- If you are located in France, contact Chauvet France.
- If you are located in Germany, contact Chauvet Germany.
- If you are located in Mexico, contact Chauvet Mexico.
- If you are located in any other country, DO NOT contact Chauvet. Instead, contact your local distributor. See [www.chauvetdj.com](http://www.chauvetdj.com) for distributors outside the U.S., U.K., Ireland, Benelux, France, Germany, or Mexico.



**If you are located outside the U.S., U.K., Ireland, Benelux, France, Germany, or Mexico, contact your distributor of record and follow their instructions on how to return Chauvet products to them. Visit our website [www.chauvetdj.com](http://www.chauvetdj.com) for contact details.**

Call the corresponding Chauvet Technical Support office and request a Return Merchandise Authorization (RMA) number before shipping the product. Be prepared to provide the model number, serial number, and a brief description of the cause for the return.

To submit a service request online, go to [www.chauvetdj.com/service-request](http://www.chauvetdj.com/service-request).

Send the merchandise prepaid, in its original box, and with its original packing and accessories. Chauvet will not issue call tags.

Clearly label the package with the RMA number. Chauvet will refuse any product returned without an RMA number.



**Write the RMA number on a properly affixed label. DO NOT write the RMA number directly on the box.**

Before sending the product, clearly write the following information on a piece of paper and place it inside the box:

- Your name
- Your address
- Your phone number
- RMA number
- A brief description of the problem

Be sure to pack the product properly. Any shipping damage resulting from inadequate packaging will be your responsibility. FedEx packing or double-boxing are recommended.



**Chauvet reserves the right to use its own discretion to repair or replace returned product(s).**

## Contact Us

General Information	Technical Support
<b>Chauvet World Headquarters</b>	
Address: 5200 NW 108th Ave. Sunrise, FL 33351 Voice: (954) 577-4455 Fax: (954) 929-5560 Toll Free: (800) 762-1084	Voice: (844) 393-7575 Fax: (954) 756-8015 Email: <a href="mailto:chauvetcs@chauvetlighting.com">chauvetcs@chauvetlighting.com</a> Website: <a href="http://www.chauvetdj.com">www.chauvetdj.com</a>
<b>Chauvet Europe Ltd</b>	
Address: Unit 1C Brookhill Road Industrial Estate Pinxton, Nottingham, UK NG16 6NT Voice: +44 (0) 1773 511115 Fax: +44 (0) 1773 511110	Email: <a href="mailto:UKtech@chauvetlighting.eu">UKtech@chauvetlighting.eu</a> Website: <a href="http://www.chauvetdj.eu">www.chauvetdj.eu</a>
<b>Chauvet Europe BVBA</b>	
Address: Stokstraat 18 9770 Kruishoutem Belgium Voice: +32 9 388 93 97	Email: <a href="mailto:BNLtech@chauvetlighting.eu">BNLtech@chauvetlighting.eu</a> Website: <a href="http://www.chauvetdj.eu">www.chauvetdj.eu</a>
<b>Chauvet France</b>	
Address: 3, Rue Ampère 91380 Chilly-Mazarin France Voice: +33 1 78 85 33 59	Email: <a href="mailto:FRtech@chauvetlighting.fr">FRtech@chauvetlighting.fr</a> Website: <a href="http://www.chauvetdj.eu">www.chauvetdj.eu</a>
<b>Chauvet Germany</b>	
Address: Bruno-Bürgel-Str. 11 28759 Bremen Germany Voice: +49 421 62 60 20	Email: <a href="mailto:DEtech@chauvetlighting.de">DEtech@chauvetlighting.de</a> Website: <a href="http://www.chauvetdj.eu">www.chauvetdj.eu</a>
<b>Chauvet Mexico</b>	
Address: Av. de las Partidas 34 - 3B (Entrance by Calle 2) Zona Industrial Lerma Lerma, Edo. de México, CP 52000 Voice: +52 (728) 690-2010	Email: <a href="mailto:servicio@chauvet.com.mx">servicio@chauvet.com.mx</a> Website: <a href="http://www.chauvetdj.mx">www.chauvetdj.mx</a>

Outside the U.S., U.K., Ireland, Benelux, France, Germany, or Mexico, contact the dealer of record. Follow the instructions to request support or to return a product. Visit our website for contact details.