

PHOS 45s pole mount – Specifications



item:.....	PHOS 45s pole mount
body:.....	steel / aluminium
weight:	4.1 kg
environmental conditions:.....	outdoors, humid interiors
ambient temperature:.....	-30° C – + 35° C
cooling:	active cooling, fan
noise level:	33 dBA
light source:	40 W High Power LED
recommended projection distance in normal room light:	13 ft
recommended projection distance in darkness:	33 ft
average lifetime of the LED (L70):.....	35,000 hours
colour temperature:.....	6,300 - 6,700 K
luminous flux of the LED:.....	2,700 lumens
gobo size / image size:	Ø 50 mm / Ø 40 mm
input voltage:	100 - 240 V AC, 50 / 60 Hz
power consumption:.....	51 W
efficiency:.....	0.5 cos. φ
electrical protection:.....	I
ingress protection rating:	IP 64
photobiological safety according to ICE62471:2006 EN62471:2008:.....	RG-2
item number:	20045610 – white, 20045620 – black, 20045630 – silver

The 40 Watt High-Power LED of PHOS 45s pole mount provides extra power. With its special holder the projector can be attached to poles or tubes and is suitable for year-round outdoor use or for damp interiors. The lens is equipped with a special gasket, which prevents the penetration of moisture. All encapsulated electronic components are waterproof. The ballast is already integrated in the housing. The projector is connected via a watertight connection tube. The recommended projection distance at dusk and night is up to 33 feet. PHOS 45s pole mount is especially suitable for outdoor projections on facades or portals, messages on pavements or areas in pedestrian zones – up to a diameter of about 13 feet. The projection motif (gobo) can be changed without tools.

Components:

Standard series with high power LED and 85 mm standard lens. Required accessories: glass gobo with individually designed motif.



Dimensions

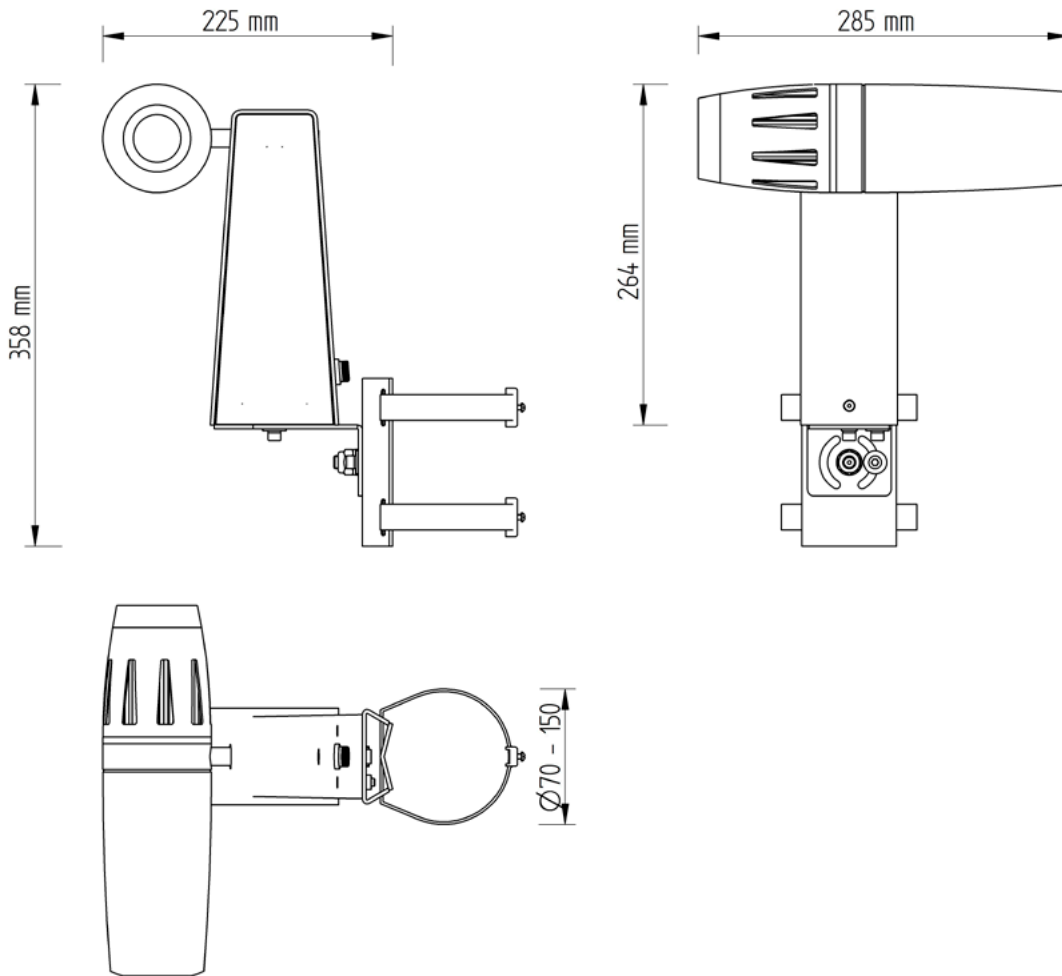

Projection Size

Standard Lens, $f = 85$ mm

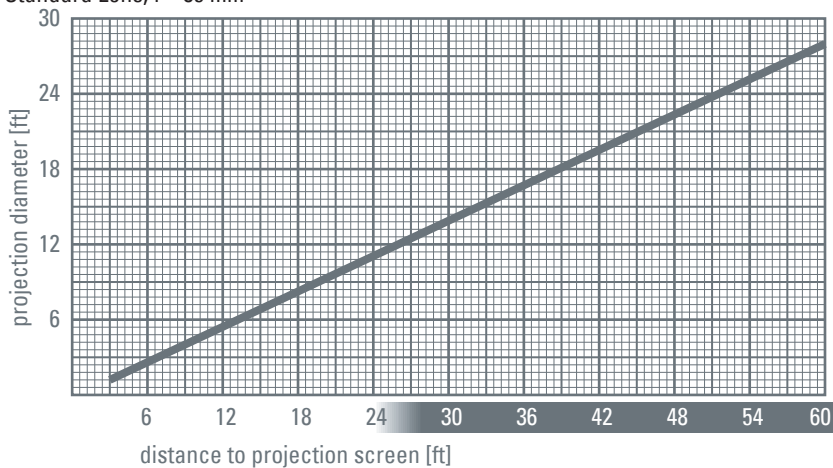

derksen®
lichttechnik

Derksen Lichttechnik GmbH
Sauerlandstraße 5
45889 Gelsenkirchen
Germany

Tel.: +49 (0)209 / 9 80 70 0
Fax: +49 (0)209 / 9 80 70 60

info@derksen.de
www.derksen.de