

COLORADO 2-QUAD ZOOM

User Manual

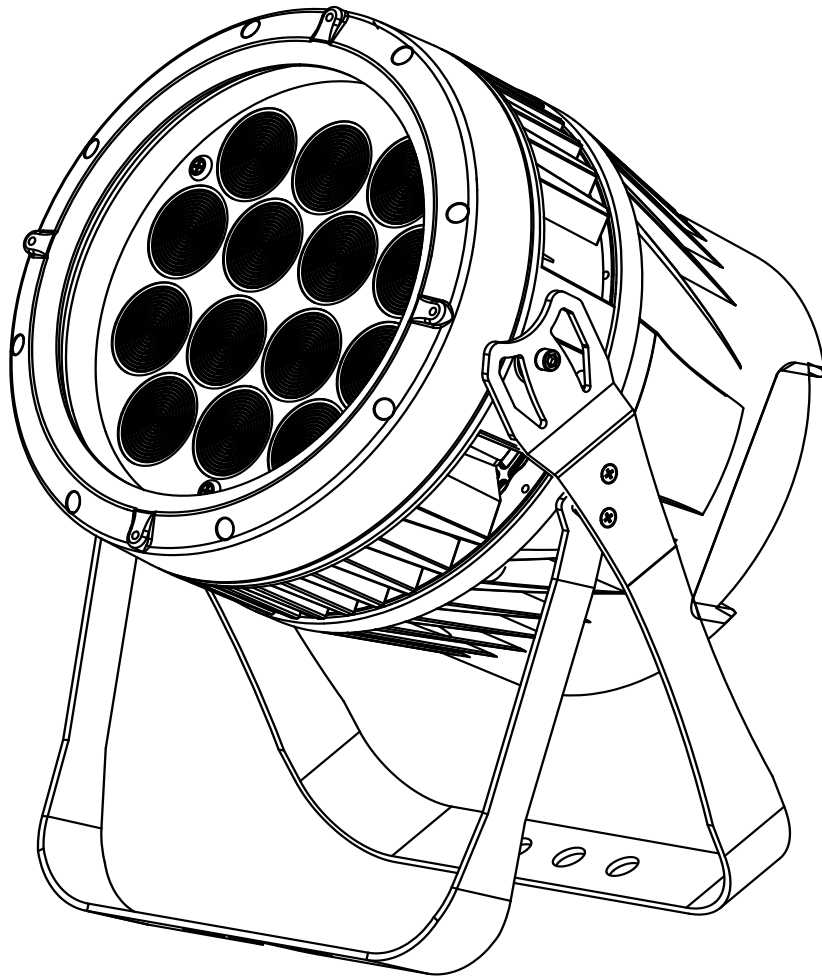

CHAUVET
PROFESSIONAL

TABLE OF CONTENTS

| | |
|----------------------------------|-----------|
| 1. Edition Notes | 1 |
| Trademarks | 1 |
| Copyright Notice..... | 1 |
| Manual Use | 1 |
| Document Printing..... | 1 |
| Intended Audience | 1 |
| Disclaimer | 1 |
| Document Revision | 1 |
| 2. Before You Begin | 2 |
| What Is Included | 2 |
| Claims | 2 |
| Manual Conventions | 2 |
| Symbols | 2 |
| Safety Notes..... | 3 |
| Personal Safety..... | 3 |
| Mounting and Rigging | 3 |
| Power and Wiring..... | 3 |
| Operation | 3 |
| Expected LED Lifespan..... | 3 |
| 3. Introduction | 4 |
| Description | 4 |
| Features..... | 4 |
| Product Overview..... | 5 |
| Product Dimensions | 6 |
| 4. Setup | 7 |
| AC Power | 7 |
| AC Plug | 7 |
| Power Linking..... | 7 |
| DMX Linking..... | 7 |
| DMX Personalities..... | 7 |
| Master/Slave Connectivity..... | 8 |
| Mounting | 8 |
| Orientation..... | 8 |
| Rigging | 8 |
| Procedure..... | 9 |
| 5. Operation | 10 |
| Control Panel Operation..... | 10 |
| Control Options | 10 |
| Programming..... | 10 |
| Control Panel Lock..... | 10 |
| Passcode | 10 |
| Menu Map | 11 |
| Configuration (DMX) | 13 |
| DMX Personalities..... | 13 |
| DMX Control..... | 13 |
| Loss Of Signal Setting..... | 13 |
| Zoom Limit Settings | 13 |
| DMX Values | 14 |
| Configuration (Standalone) | 19 |
| Auto Programs | 19 |

TABLE OF CONTENTS

| | |
|--|-----------|
| Edit Custom Programs | 19 |
| Master/Slave | 19 |
| Color Settings..... | 19 |
| Dimmer Profiles..... | 20 |
| Curve Settings..... | 20 |
| Program Upload | 20 |
| Reset..... | 21 |
| Whites Setting | 21 |
| White Calibration..... | 21 |
| Static Color..... | 21 |
| 6. Technical Information | 22 |
| Product Maintenance | 22 |
| 7. Technical Specifications | 23 |
| Photometrics Chart | 24 |
| Returns..... | 25 |
| Contact Us | 26 |

1. EDITION NOTES

The Colorado 2 Quad Zoom User Manual includes a description, safety precautions, installation, programming, operation and maintenance instructions for the Colorado 2 Quad Zoom as of the release date of this edition.

Trademarks

CHAUVET, the Chauvet logo and Colorado 2 Quad Zoom are registered trademarks or trademarks of Chauvet & Sons, LLC (d/b/a Chauvet and Chauvet Lighting) in the United States and other countries. Other company and product names and logos referred to herein may be trademarks of their respective companies.

Copyright Notice

The works of authorship contained in this manual, including, but not limited to, all design, text and images are owned by Chauvet.

© Copyright 2019 Chauvet & Sons, LLC. All rights reserved.

Electronically published by Chauvet in the United States of America.

Manual Use

Chauvet authorizes its customers to download and print this manual for professional information purposes only. Chauvet expressly prohibits the usage, copy, storage, distribution, modification, or printing of this manual or its content for any other purpose without written consent from Chauvet.

Document Printing

For best results, print this document in color, on letter size paper (8.5 x 11 in), double-sided. If using A4 paper (210 x 297 mm), configure the printer to scale the content accordingly.

Intended Audience

Any person installing, operating, and/or maintaining this product should completely read through the guide that shipped with the product, as well as this manual, before installing, operating, or maintaining this product.

Disclaimer

Chauvet believes that the information contained in this manual is accurate in all respects. However, Chauvet assumes no responsibility and specifically disclaims any and all liability to any party for any loss, damage or disruption caused by any errors or omissions in this document, whether such errors or omissions result from negligence, accident or any other cause. Chauvet reserves the right to revise the content of this document without any obligation to notify any person or company of such revision, however, Chauvet has no obligation to make, and does not commit to make, any such revisions. Download the latest version from www.chauvetprofessional.com

Document Revision

This Colorado 2 Quad Zoom User Manual is the 2nd edition of this document. Go to www.chauvetprofessional.com for the latest version.

2. BEFORE YOU BEGIN

What Is Included

- Colorado 2 Quad Zoom
- Seetronic Powerkon IP65 power cord
- Gel frame
- Gel frame holder (7.5 in/191 mm accessories)
- Warranty Card
- Quick Reference Guide

Claims

Carefully unpack the product immediately and check the container to make sure all the parts are in the package and are in good condition.





If the box or the contents (the product and included accessories) appear damaged from shipping, or show signs of mishandling, notify the carrier immediately, not Chauvet. Failure to report damage to the carrier immediately may invalidate your claim. In addition, keep the box and contents for inspection.

For other issues, such as missing components or parts, damage not related to shipping, or concealed damage, file a claim with Chauvet within 7 days of delivery.

Manual Conventions

| Convention | Meaning |
|------------|---|
| 1–512 | A range of values |
| 50/60 | A set of values of which only one can be chosen |
| <SET> | A button on the product's control panel |
| Settings | A product function or a menu option |

Symbols

| Symbol | Meaning |
|---|---|
|  | Electrical warning. Not following these instructions may cause electrical damage to the product, accessories, or the user. |
|  | Critical installation, configuration, or operation information. Not following these instructions may make the product not work, cause damage to the product, or cause harm to the operator. |
|  | Important installation or configuration information. The product may not function correctly if this information is not used. |
|  | Useful information. |



Any reference to data or power connections in this manual assumes the use of Seetronic IP rated cables.



The term “DMX” used throughout this manual refers to the USITT DMX512-A digital data transmission protocol.

Safety Notes

Read all the following safety notes before working with this product. These notes contain important information about the installation, usage, and maintenance of this product.



This product contains no user-serviceable parts. Any reference to servicing in this User Manual will only apply to properly trained, certified technicians. Do not open the housing or attempt any repairs.



All applicable local codes and regulations apply to proper installation of this product.

Personal Safety

- Avoid direct eye exposure to the light source while the product is on.
- Always disconnect the product from the power source before cleaning.
- Always connect the product to a grounded circuit to avoid the risk of electrocution.
- Do not touch the product's housing when operating because it may be very hot.

Mounting and Rigging

- Do not submerge this product (IP65). Temporary outdoor operation is fine.
- When using this product in an outdoor environment, use IP65 (or higher) rated power and data cables. Secure unused power and data ports with attached IP65 covers.
- CAUTION: When transferring product from extreme temperature environments, (e.g., cold truck to warm, humid ballroom) condensation may form on the internal electronics of the product. To avoid causing a failure, allow product to fully acclimate to the surrounding environment before connecting it to power.
- Not for permanent outdoor installation in locations with extreme environmental conditions. This includes, but is not limited to:
 - Exposure to a marine/saline environment (within 3 miles of a saltwater body of water).
 - Locations where the normal high or low temperatures exceed the temperature ranges in this manual.
 - Locations that are prone to flooding or being buried in snow.
 - Areas where the product will be subjected to extreme radiation or caustic substances.
- Mount this product in a location with adequate ventilation, at least 20 in (50 cm) from adjacent surfaces.
- Make sure there are no flammable materials close to the product when operating.
- When hanging this product, always secure to a fastening device using a safety cable.

Power and Wiring

- Always make sure you are connecting the product to the proper voltage in accordance with the specifications in this manual or on the product's specification label.
- Never connect the product to a dimmer pack or rheostat.
- Never disconnect this product by pulling or tugging on the power cable.

Operation

- Do not operate this product if there is damage on the housing, lenses, or cables. Have the damaged parts replaced by an authorized technician at once.
- Do not cover the ventilation slots when operating to avoid internal overheating.
- The maximum ambient temperature is 113 °F (45 °C). Do not operate the product at higher temperatures.
- In the event of a serious operation problem, stop using this product immediately!



If your Chauvet product requires service, contact Chauvet Technical Support.

Expected LED Lifespan

LEDs gradually decline in brightness over time, primarily because of heat. LEDs that are arranged in clusters experience higher operating temperatures than single LEDs. For this reason, operating clustered LEDs at their fullest intensity significantly reduces the LEDs' lifespan. Under normal conditions, this lifespan is 40,000 to 50,000 hours. If extending this lifespan is vital, lower the operating temperature by improving the ventilation around the product, thus reducing the ambient temperature. In addition, limiting the overall projection intensity may extend the LEDs' lifespan.

3. INTRODUCTION

Description

The Colorado 2 Quad Zoom is a ruggedly built wash light with 14 high-output RGBW LEDs. IP-rated power and data connectors allow for easy connections. Using IP-rated DMX cables allows the fixture to maintain its IP65 rating, but standard 3- or 5-pin XLR DMX cables work perfectly for indoor use. A 14° to 44° zoom gives you beam control in a multitude of application, and selectable dimming curves allow the user to integrate the product into any existing rig.

Features

- 3-, 4-, 5-, 6-, 7-, 12-, or 17-channel quad-color LED wash product
- Operating modes:
 - 3-channel: RGB control
 - 3-channel: HSV control
 - 4-channel: RGB, dimmer
 - 4-channel: RGBW
 - 5-channel: RGBW, dimmer
 - 6-channel: RGBW, dimmer, strobe
 - 7-channel: RGBW, dimmer, zoom, zoom reset
 - 12-channel: RGBW, dimmer, strobe, color macro, auto/custom, dimmer speed, auto speed, zoom, zoom reset
 - 17-channel: 16-bit RGBW and dimmer; strobe, color macro, auto/custom, dimmer speed, auto speed, zoom, zoom reset
- Built-in auto and custom programs recalled via DMX and Master/Slave
- RGBW color mixing via DMX or manually
- Zoomable, with a wide zoom range for design versatility
- Tough road-ready construction
- Selectable, smooth dimming curves for programming versatility
- 16-bit dimming of individual colors and master dimmer
- All-environment operation with IP-rated power and DMX connections
- 3- and 5-pin DMX input/output connections
- Double-bracket yoke doubles as floor stand

Product Overview

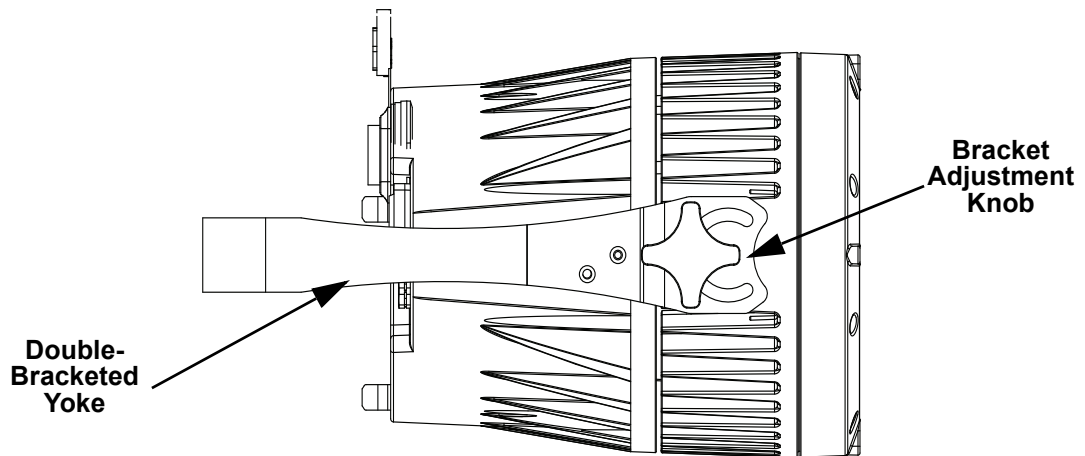
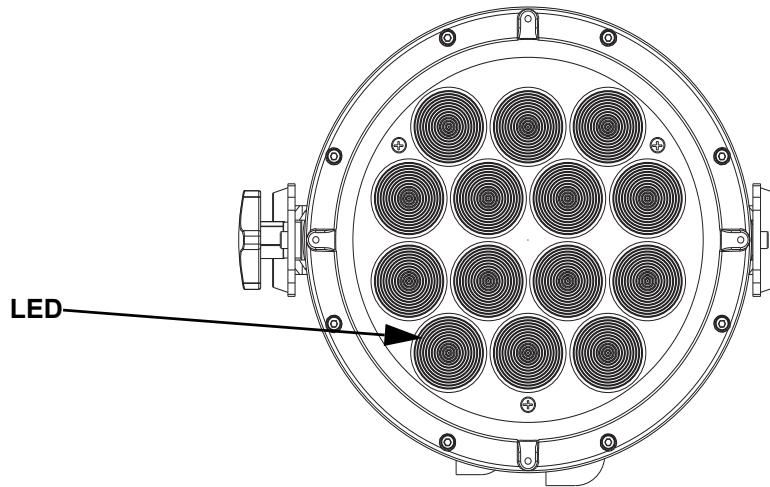
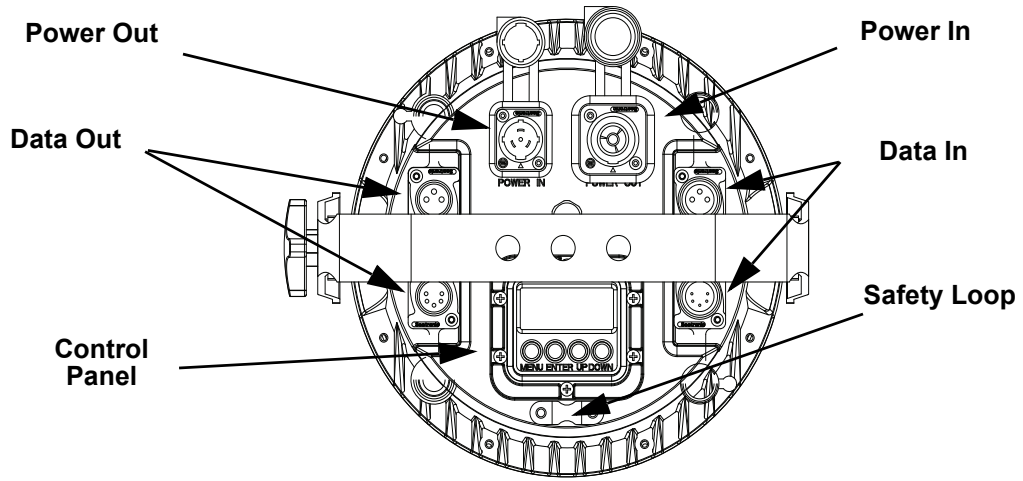

Product Dimensions

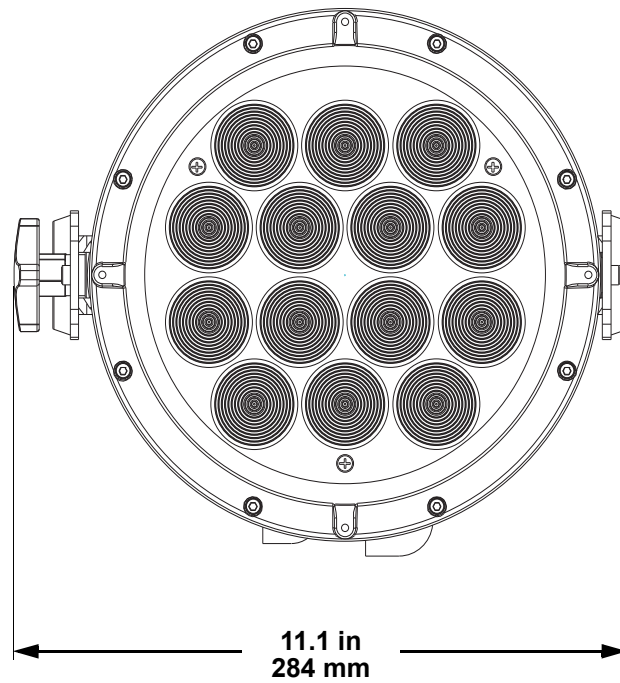
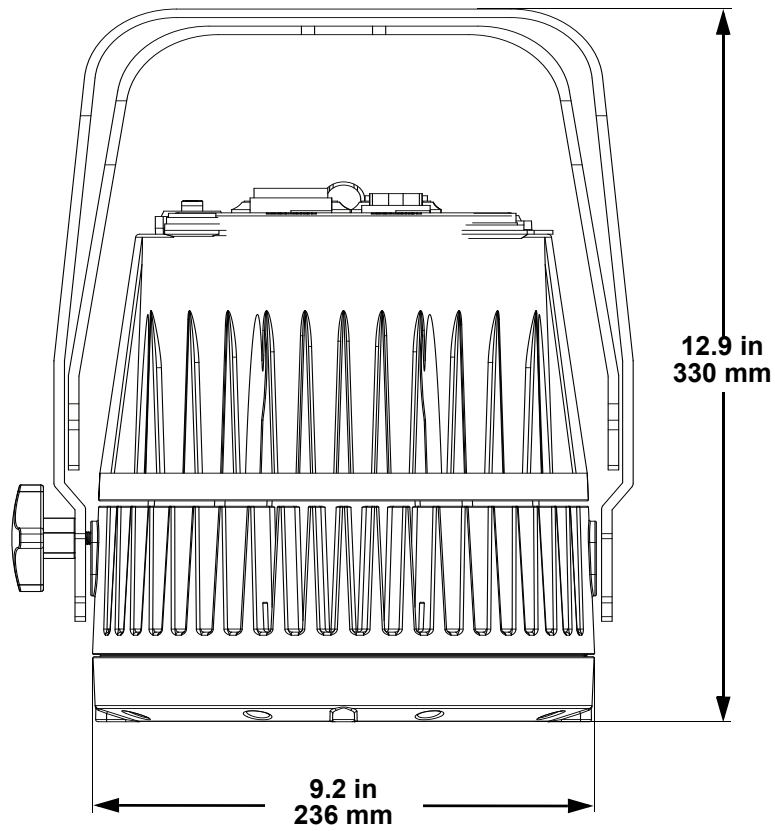

4. SETUP

AC Power

Each Colorado 2 Quad Zoom has an auto-ranging power supply that works with an input voltage range of 100 to 240 VAC, 50/60 Hz. To determine the power requirements for each Colorado 2 Quad Zoom, refer to the label affixed to the product. You can also refer to the Technical Specifications chart in this manual.

The listed current rating indicates the maximum current draw during normal operation. For more information, download Sizing Circuit Breakers from the Chauvet website: www.chauvetprofessional.com.



- **Always connect the product to a protected circuit (e.g., circuit breaker or fuse). Make sure the product has an appropriate electrical ground to avoid the risk of electrocution or fire.**
- **To eliminate unnecessary wear and improve its lifespan, during periods of non-use completely disconnect the product from power via breaker or by unplugging it.**



Never connect the product to a rheostat (variable resistor) or dimmer circuit, even if the rheostat or dimmer channel serves only as a 0 to 100% switch.

AC Plug

The Colorado 2 Quad Zoom comes with a power input cord terminated with a Seetronic Powerkon A connector on one end and an Edison plug on the other end (U.S. market). If the power input cord that came with your product has no plug, or if you need to change the plug, use the table below to wire the new plug.

| Connection | Wire (U.S.) | Wire (Europe) | Screw Color |
|------------|--------------|---------------|-----------------|
| AC Live | Black | Brown | Yellow or Brass |
| AC Neutral | White | Blue | Silver |
| AC Ground | Green/Yellow | Green/Yellow | Green |

Power Linking

The product supports power linking. You can power link up to 7 products at 120 V; up to 12 at 208 V; or up to 13 at 230 V.

This product comes with a power input cord. Power-linking cables are available from Chauvet for purchase.



- **To preserve the IP65 rating and the warranty of this product Seetronic Powerkon cables must be used.**
- **Insert the attached IP65 rated plugs into the corresponding power/data connections when not in use.**

DMX Linking

You can link the Colorado 2 Quad Zoom to a DMX controller using a 3- or 5-pin DMX connection. If using other DMX-compatible products with this product, you can control each individually with a single DMX controller.

DMX Personalities

The Colorado 2 Quad Zoom uses a 3- or 5-pin DMX data connection for the 3-, 4-, 5-, 6-, 7-, 12-, and 17-channel DMX personalities.

- Refer to the [Introduction](#) for a brief description of each DMX personality.
- Refer to the [Operation](#) chapter to learn how to configure the Colorado 2 Quad Zoom to work in these personalities.
- The [DMX Values](#) section provides detailed information regarding the DMX personalities.



If you are not familiar with or need more information about DMX standards, Master/Slave connectivity, or the DMX cables needed to link this product to a DMX controller, download the DMX Primer from the Chauvet website: www.chauvetprofessional.com.

Master/Slave Connectivity

The Master/Slave mode allows a Colorado 2 Quad Zoom (the master) to control one or more Colorado 2 Quad Zoom products (the slaves) without a DMX controller. One Colorado 2 Quad Zoom becomes the master when running an auto or custom program, or by being in a Static mode.

You must configure each slave's control panel to operate in Slave mode. During Master/Slave operation, the slaves will operate in unison with the master.



DO NOT connect a DMX controller to products operating in Master/Slave mode. The DMX controller signals may interfere with the signals from the master.



- The [Operation](#) section of this manual provides detailed instructions on how to configure the master and slaves.
- If you are not familiar with or need more information about DMX standards, or the DMX cables needed to link this product to a DMX controller, download the DMX Primer from the Chauvet website: www.chauvetprofessional.com.



- To preserve the IP65 rating and the warranty of this product, IP65 data cables must be used.
- Insert the attached IP65-rated plugs into the corresponding power/data connections when not in use.

Mounting

Before mounting the product, read and follow the safety recommendations indicated in the Safety Notes. For our CHAUVET Professional line of mounting clamps, go to <http://trusst.com/products/>.

Orientation

Always mount this product in a safe position, making sure there is adequate room for ventilation, configuration, and maintenance.

Rigging

Chauvet recommends using the following general guidelines when mounting this product.

- Before deciding on a location for the product, make sure there is easy access to the product for maintenance and programming purposes.
- Make sure that the structure onto which you are mounting the product can support the product's weight. See the [Technical Specifications](#) for weight information.
- When mounting the product overhead, always use a safety cable. Mount the product securely to a rigging point, whether an elevated platform or a truss.
- When rigging the product onto a truss, use a mounting clamp of appropriate weight capacity.
- When power linking multiple products, mount the products close enough for power linking cables to reach.
- The bracket adjustment knobs allow for directional adjustment when aiming the product to the desired angle. Only loosen or tighten the bracket knobs manually. Using tools could damage the knobs.

Procedure

The Colorado 2 Quad Zoom comes with a double-bracketed yoke to which you can either attach mounting clamps for hanging or simply use as a floor stand. You must supply the mounting clamps. Make sure the clamps are capable of supporting the weight of this product. Use at least one mounting point per product. For the CHAUVET Professional line of mounting clamps, go to <http://trusst.com/products/>.

Mounting Diagram

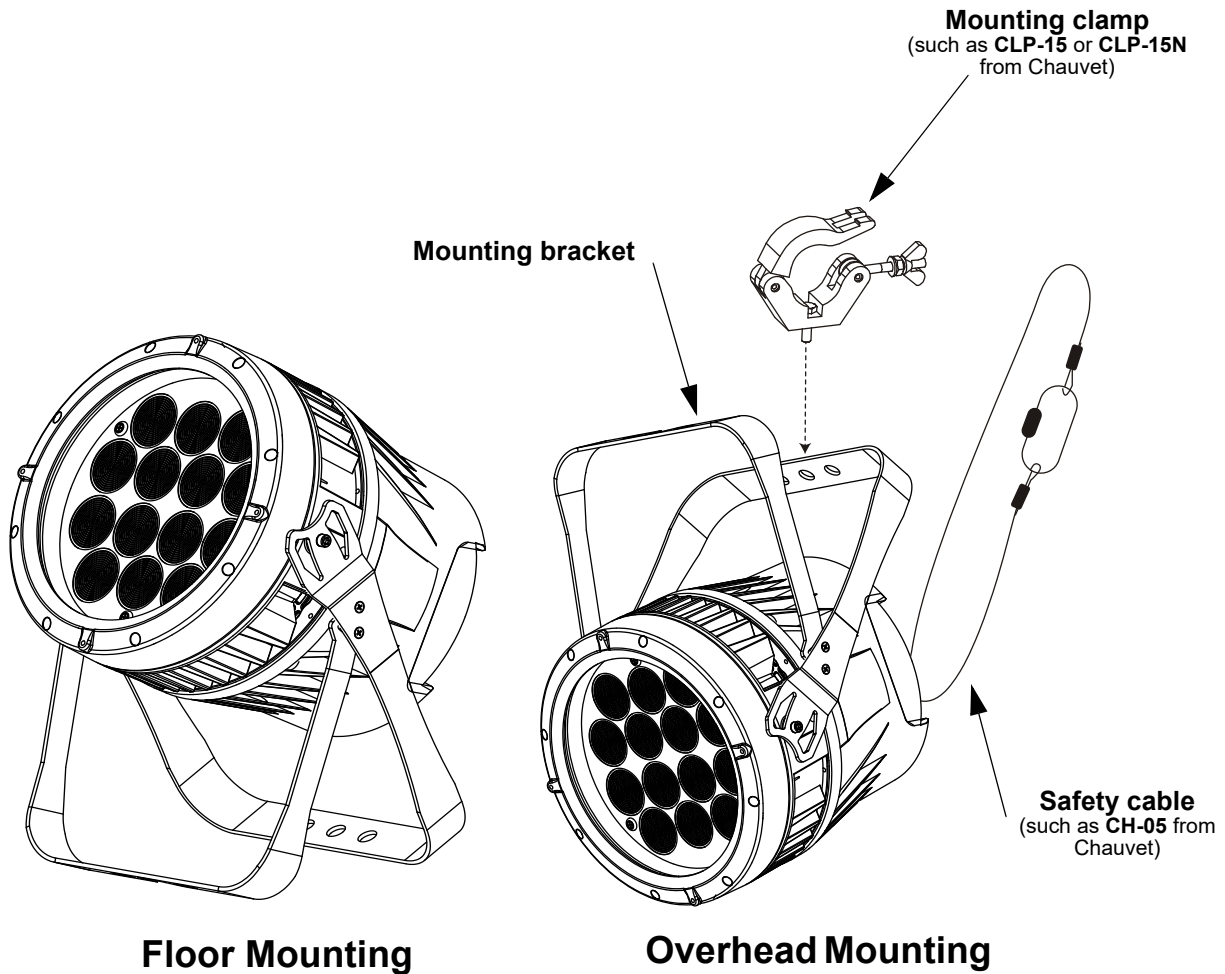

5. OPERATION

Control Panel Operation

| Button | Function |
|---------|--|
| <MENU> | Exits from the current menu or function |
| <ENTER> | Enables the currently displayed menu or sets the currently selected value in to the current function |
| <UP> | Navigates upward through the menu list or increases the numeric value when in a function |
| <DOWN> | Navigates downward through the menu list or decreases the numeric value when in a function |

Control Options

Set the Colorado 2 Quad Zoom starting address in the 001-512 DMX range. This enables control of up to 30 products in the 17-channel TR16 personality.

Programming

Refer to the [Menu Map](#) to understand the menu options. The menu map shows the main level and a variable number of programming levels for each option.

- To go to the desired main level, press <MENU> repeatedly until the option shows on the display. Press <ENTER> to select. This will take you to the first programming level for that option.
- To select an option or value within the current programming level, press <UP> or <DOWN> until the option shows on the display. Press <ENTER> to select. In this case, if there is another programming level, you will see that first option, or you will see the selected value.
- Press <MENU> repeatedly to exit to the previous main level.

Control Panel Lock

This setting enables you to activate or disable the control panel lock, which keeps unauthorized users from changing the product's settings.

1. Go to the **KEY** main level.
2. Select **ON** or **OFF**.



When the control panel lock is activated, in order to access the products main programming level, the product will prompt for the passcode. Enter the passcode as described below.

Passcode

After being prompted to enter the passcode:

Press <UP>, <DOWN>, <UP>, <DOWN>, <ENTER>

Menu Map

| Main Level | Programming Levels | | | Description | | |
|------------|--------------------|----------|--|--|--|--|
| STAT | | R. | 0-255 | Combines red, green, blue, and white to make a custom color (0-100%) | | |
| | | G. | | | | |
| | | B. | | | | |
| | | W. | | | | |
| | | Z. | | Changes the beam angle (zoom) | | |
| | S. | 0-20 | Selects the strobe frequency (0-20 Hz) | | | |
| AUTO | AT. 1-10 | | | Selects automatic programs and auto program speed | | |
| | PR 1-10 | | | Selects customizable programs | | |
| RUN | DMX | | | Receives DMX signals from the DMX controller | | |
| | SLAVE | | | Receives DMX signals from the master | | |
| DMX | D. 001-512 | | | Sets the DMX starting address | | |
| PERS | TR16 | | | 17-channel: 16-bit RGBW and dimmer; strobe, color macro, auto/custom, dimmer speed, auto speed, zoom, zoom reset | | |
| | STD.Y | | | 17-channel: 16-bit RGBW and dimmer; strobe, color macro, auto/custom, dimmer speed, auto speed, zoom, zoom reset | | |
| | TOUR | | | 12-channel: RGBW, dimmer, strobe, color macro, auto/custom, dimmer speed, auto speed, zoom, zoom reset | | |
| | AR2.Z | | | 7-channel: RGBW, dimmer, zoom, zoom reset | | |
| | AR2.S | | | 6-channel: RGBW, dimmer, strobe | | |
| | AR2.D | | | 5-channel: RGBW, dimmer | | |
| | ARC.2 | | | 4-channel: RGBW | | |
| | AR1.D | | | 4-channel: RGB, dimmer | | |
| | ARC.1 | | | 3-channel: RGB control | | |
| | HSV. | | | 3-channel: HSV control | | |
| EDIT | PR. 1-10 | SC.01-30 | R. | 0-255 | Combines red, green, blue, and white to make a custom color (0-100%) | |
| | | | G. | | | |
| | | | B. | | | |
| | | | W. | | | |
| | | | Z. | | Changes the beam angle (zoom) | |
| | | | S. | | 0-20 | Selects the strobe frequency (0-20 Hz) |
| | | | T. | | 0-255 | Defines the step duration (slow to fast) |
| | | | F. | | | Defines the fade duration (slow to fast) |

| Main Level | Programming Levels | | | | Description | | |
|------------|--------------------------|------|--------------------------|--|---|---------|---|
| SET | UPLD | | **** (Enter Passcode) | | Uploads custom programs to other Colorado 2 Quad Zoom | | |
| | REST | | | | Resets the fixture to factory defaults | | |
| | COLR | | OFF | | RGB set to 255 = max. output | | |
| | | | RGBW | | RGB set to 255 = balanced white | | |
| | | | UC. | | Universal color balance | | |
| | DIM | | OFF | | Selects dimming profiles from fast (DIM1) to slow (DIM4) or OFF | | |
| | | | DIM1 | | | | |
| | | | DIM2 | | | | |
| | | | DIM3 | | | | |
| | CURV | | DIM4 | | No dimmer | | |
| | | | OFF | | | | |
| | | | CV1 | | | | |
| | | | CV2 | | | | |
| | DERR | | CV3 | | Dimmer curves fast (CV1) to slow (CV3) | | |
| SAVE | | | | | | | |
| BLAC | | | | | | | |
| ZOOM | | BASE | | Continues with last command upon loss of DMX control | | | |
| | | POS1 | | Blacks out fixture upon loss of DMX | | | |
| | | POS2 | | Sets default zoom position (full movement) | | | |
| CAL | **** (Enter Passcode) | CAL | WT | WH 01-11 | R. | 000-255 | Modifies the color macros used in the TOUR, STD.Y, and TR16 personalities |
| | | | | | G. | | |
| | | | | | B. | | |
| | | | | | W. | | |
| | | | RG BW | RGB.W | R. | | Defines the color temperature used when COLOR is set to RGBW |
| | | | | | G. | | |
| | | | | | B. | | |
| | | | ZOOM | | POS.1 | | Sets the min/max position of the zoom function |
| | | | | | POS.2 | | |
| | | | KEY | OFF | | | |
| ON | | | | | | | |

Configuration (DMX)

Use DMX configurations to operate the product with a DMX controller.

DMX Personalities

This setting allows you to choose a particular DMX personality.

1. Go to the **PERS** main level.
2. Select the desired personality (**TOUR**, **TR16**, **STD.Y**, **ARC.1**, **AR1.D**, **ARC.2**, **AR2.D**, **AR2.S**, **AR2.Z**, or **HSV**).



- See the [DMX Values](#) section for the highest starting address you can select for each personality.
- Make sure that the starting addresses on the various products do not overlap due to the new personality setting.

DMX Control

In this mode, each product will respond to a unique starting address from the DMX controller. All products with the same starting address will respond in unison.

1. Select a DMX personality as shown in [DMX Personalities](#).
2. Set the running mode:
 - a. Go to the **RUN** main level.
 - b. Select the **DMX** programming level.
3. Set the starting address:
 - a. Go to **DMX** main level.
 - b. Select the starting address (**001–512**)

The highest recommended starting address for each DMX mode is as follows:

| DMX Personality | DMX Address | DMX Personality | DMX Address |
|-----------------|-------------|-----------------|-------------|
| TOUR | 501 | AR2.S | 507 |
| ARC.1 | 510 | HSV | 510 |
| AR1.D | 509 | TR16 | 496 |
| ARC.2 | 509 | STD.Y | 496 |
| AR2.D | 508 | AR2.Z | 506 |

Loss Of Signal Setting

This setting controls how the product will respond when the DMX signal is lost.

1. Go to the **SET** main level.
2. Select **DERR**.
 - a. Select **SAVE** to make the product use the last command used when the signal is lost.
 - b. Select **BLAC** to turn off the all the LEDs when the signal is lost.

Zoom Limit Settings

These settings allow you to select the zoom range. Basic zoom (**BASE**) is the default setting which allows the zoom to move at full range (**000–255**) and has no adjustable limit. Position 1 (**POS.1**) and Position 2 (**POS.2**) allow you to set limits on how far the zoom moves.

1. Set the zoom range to be used:
 - a. Go to the **SET** main level.
 - b. Select **ZOOM**.
 - c. Select **BASE**, **POS.1**, or **POS.2**.
2. Set the limit for zoom range **POS.1** or **POS.2**:
 - a. Go to the **CAL** main level.
 - b. Enter the master access passcode as described in Passcode.
 - c. When **CAL** shows, press <UP>.
 - d. Go to **ZOOM**.
 - e. Select **POS.1** or **POS.2**.
 - f. Select a zoom limit value (**000–255**).

DMX Values

| TR16 | Channel | Function | Value | Percent/Setting |
|------|---------|-----------------------------|---|--|
| | 1 | Dimmer | 000 ⇔ 255 | 0-100% |
| | 2 | Fine Dimmer | 000 ⇔ 255 | Fine control (16-bit) (Step Duration if Custom 1–10 in CH. 13 is active) |
| | 3 | Red | 000 ⇔ 255 | 0-100% (Fade Duration if Custom 1–10 in CH. 13 is active) |
| | 4 | Fine Red | 000 ⇔ 255 | Fine control (16-bit) |
| | 5 | Green | 000 ⇔ 255 | 0-100% |
| | 6 | Fine Green | 000 ⇔ 255 | Fine control (16-bit) |
| | 7 | Blue | 000 ⇔ 255 | 0-100% |
| | 8 | Fine Blue | 000 ⇔ 255 | Fine control (16-bit) |
| | 9 | White | 000 ⇔ 255 | 0-100% |
| | 10 | Fine White | 000 ⇔ 255 | Fine control (16-bit) |
| | 11 | Color Macro + White Balance | 000 ⇔ 010 011 ⇔ 030 031 ⇔ 050 051 ⇔ 070 071 ⇔ 090 091 ⇔ 110 111 ⇔ 130 131 ⇔ 150 151 ⇔ 170 171 ⇔ 200 201 ⇔ 205 206 ⇔ 210 211 ⇔ 215 216 ⇔ 220 221 ⇔ 225 226 ⇔ 230 231 ⇔ 235 236 ⇔ 240 241 ⇔ 245 246 ⇔ 251 251 ⇔ 255 | No function R:100% G: 0-100% B: 0 R:100%-0 G: 100% B: 0 R:0 G: 100% B: 0-100% R:0 G: 100%-0 B: 100% R:0-100% G: 0 B: 100% R:100% G: 0 B: 100%-0 R:100% G: 0-100% B: 0-100% R:100%-0 G: 100%-0 B: 100% RGBW: 100% White 1 White 2 White 3 White 4 White 5 White 6 White 7 White 8 White 9 White 10 White 11 |
| | 12 | Strobe | 000 ⇔ 009 010 ⇔ 255 | No function 0-20 Hz |
| | 13 | Programs | 000 ⇔ 040 041 ⇔ 050 051 ⇔ 060 061 ⇔ 070 071 ⇔ 080 081 ⇔ 090 091 ⇔ 100 101 ⇔ 110 111 ⇔ 120 121 ⇔ 130 131 ⇔ 140 141 ⇔ 150 151 ⇔ 160 161 ⇔ 170 171 ⇔ 180 181 ⇔ 190 191 ⇔ 200 201 ⇔ 210 211 ⇔ 220 221 ⇔ 230 231 ⇔ 255 | No function Auto 1 Auto 2 Auto 3 Auto 4 Auto 5 Auto 6 Auto 7 Auto 8 Auto 9 Auto 10 Custom 1 Custom 2 Custom 3 Custom 4 Custom 5 Custom 6 Custom 7 Custom 8 Custom 9 Custom 10 |
| | 14 | Auto Speed | 000 ⇔ 255 | 0-100% (only when using Auto 1–10 in CH. 13) |

| TR16 | Channel | Function | Value | Percent/Setting |
|-----------|-----------|-----------------------------|-------------------------------------|--|
| | 15 | Dimmer Speed | 000 ⇔ 009 | Preset dimmer speed from display menu |
| | | | 010 ⇔ 029 | Linear dimmer |
| | | | 030 ⇔ 069 | Nonlinear dimming curve 1 (fastest) |
| 070 ⇔ 129 | | | Nonlinear dimming curve 2 | |
| 130 ⇔ 189 | | | Nonlinear dimming curve 3 | |
| 190 ⇔ 255 | | | Nonlinear dimming curve 4 (slowest) | |
| | 16 | Zoom | 000 ⇔ 255 | 0-100% |
| | 17 | Zoom Control | 000 ⇔ 200 | No function |
| | | | 201 ⇔ 220 | Zoom reset |
| | | | 221 ⇔ 255 | No function |
| STD.Y | Channel | Function | Value | Percent/Setting |
| | 1 | Dimmer | 000 ⇔ 255 | 0-100% |
| | 2 | Fine Dimmer | 000 ⇔ 255 | Fine control (16-bit) (Step Duration if Custom 1–10 in CH. 13 is active) |
| | 3 | Red | 000 ⇔ 255 | 0-100% (Fade Duration if Custom 1–10 in CH. 13 is active) |
| | 4 | Fine Red | 000 ⇔ 255 | Fine control (16-bit) |
| | 5 | Green | 000 ⇔ 255 | 0-100% |
| | 6 | Fine Green | 000 ⇔ 255 | Fine control (16-bit) |
| | 7 | Blue | 000 ⇔ 255 | 0-100% |
| | 8 | Fine Blue | 000 ⇔ 255 | Fine control (16-bit) |
| | 9 | White | 000 ⇔ 255 | 0-100% |
| | 10 | Fine White | 000 ⇔ 255 | Fine control (16-bit) |
| | 11 | Color Macro + White Balance | 000 ⇔ 010 | No function |
| | | | 011 ⇔ 030 | R:100% G: 0-100% B: 0 |
| | | | 031 ⇔ 050 | R:100%-0 G: 100% B: 0 |
| | | | 051 ⇔ 070 | R:0 G: 100% B: 0-100% |
| | | | 071 ⇔ 090 | R:0 G: 100%-0 B: 100% |
| | | | 091 ⇔ 110 | R:0-100% G: 0 B: 100% |
| | | | 111 ⇔ 130 | R:100% G: 0 B: 100%-0 |
| | | | 131 ⇔ 150 | R:100% G: 0-100% B: 0-100% |
| | | | 151 ⇔ 170 | R:100%-0 G: 100%-0 B: 100% |
| | | | 171 ⇔ 200 | RGBW: 100% |
| | | | 201 ⇔ 205 | White 1 |
| | | | 206 ⇔ 210 | White 2 |
| | | | 211 ⇔ 215 | White 3 |
| | | | 216 ⇔ 220 | White 4 |
| | | | 221 ⇔ 225 | White 5 |
| | | | 226 ⇔ 230 | White 6 |
| | | | 231 ⇔ 235 | White 7 |
| | 236 ⇔ 240 | White 8 | | |
| | 241 ⇔ 245 | White 9 | | |
| | 246 ⇔ 251 | White 10 | | |
| | 251 ⇔ 255 | White 11 | | |
| | 12 | Strobe | 000 ⇔ 009 | No function |
| | | | 010 ⇔ 255 | 0-20 Hz |

| STD.Y | Channel | Function | Value | Percent/Setting |
|-----------|-------------------------------------|-----------|---|-----------------|
| | 13 | Programs | 000 ⇄ 040 | No function |
| | | | 041 ⇄ 050 | Auto 1 |
| | | | 051 ⇄ 060 | Auto 2 |
| | | | 061 ⇄ 070 | Auto 3 |
| | | | 071 ⇄ 080 | Auto 4 |
| | | | 081 ⇄ 090 | Auto 5 |
| | | | 091 ⇄ 100 | Auto 6 |
| | | | 101 ⇄ 110 | Auto 7 |
| | | | 111 ⇄ 120 | Auto 8 |
| | | | 121 ⇄ 130 | Auto 9 |
| | | | 131 ⇄ 140 | Auto 10 |
| | | | 141 ⇄ 150 | Custom 1 |
| | | | 151 ⇄ 160 | Custom 2 |
| | | | 161 ⇄ 170 | Custom 3 |
| | | | 171 ⇄ 180 | Custom 4 |
| | 181 ⇄ 190 | Custom 5 | | |
| | 191 ⇄ 200 | Custom 6 | | |
| | 201 ⇄ 210 | Custom 7 | | |
| | 211 ⇄ 220 | Custom 8 | | |
| | 221 ⇄ 230 | Custom 9 | | |
| | 231 ⇄ 255 | Custom 10 | | |
| 14 | Auto Speed | 000 ⇄ 255 | 0-100% (only when using Auto 1–10 in CH. 13) | |
| 15 | Dimmer Speed | 000 ⇄ 009 | Preset dimmer speed from display menu | |
| | | 010 ⇄ 029 | Linear dimmer | |
| | | 030 ⇄ 069 | Nonlinear dimming curve 1 (fastest) | |
| | | 070 ⇄ 129 | Nonlinear dimming curve 2 | |
| | | 130 ⇄ 189 | Nonlinear dimming curve 3 | |
| 190 ⇄ 255 | Nonlinear dimming curve 4 (slowest) | | | |
| 16 | Zoom | 000 ⇄ 255 | 0-100% | |
| 17 | Zoom Control | 000 ⇄ 200 | No function | |
| | | 201 ⇄ 220 | Zoom reset | |
| | | 221 ⇄ 255 | No function | |

| TOUR | Channel | Function | Value | Percent/Setting |
|------|---------|-----------------------------|-----------|--|
| | 1 | Dimmer | 000 ⇄ 255 | 0-100% |
| | 2 | Red | 000 ⇄ 255 | 0-100% (Step Duration if Custom 1–10 in CH. 8 is active) |
| | 3 | Green | 000 ⇄ 255 | 0-100% (Fade Duration if Custom 1–10 in CH. 8 is active) |
| | 4 | Blue | 000 ⇄ 255 | 0-100% |
| | 5 | White | 000 ⇄ 255 | 0-100% |
| | 6 | Color Macro + White Balance | 000 ⇄ 010 | No function |
| | | | 011 ⇄ 030 | R:100% G: 0-100% B: 0 |
| | | | 031 ⇄ 050 | R:100%-0 G: 100% B: 0 |
| | | | 051 ⇄ 070 | R:0 G: 100% B: 0-100% |
| | | | 071 ⇄ 090 | R:0 G: 100%-0 B: 100% |
| | | | 091 ⇄ 110 | R:0-100% G: 0 B: 100% |
| | | | 111 ⇄ 130 | R:100% G: 0 B: 100%-0 |
| | | | 131 ⇄ 150 | R:100% G: 0-100% B: 0-100% |
| | | | 151 ⇄ 170 | R:100%-0 G: 100%-0 B: 100% |
| | | | 171 ⇄ 200 | RGBW: 100% |

| TOUR | Channel | Function | Value | Percent/Setting |
|-----------|-------------------------------------|-----------------------------|--|--|
| | 6 | Color Macro + White Balance | 201 ⇔ 205 | White 1 |
| | | | 206 ⇔ 210 | White 2 |
| | | | 211 ⇔ 215 | White 3 |
| | | | 216 ⇔ 220 | White 4 |
| | | | 221 ⇔ 225 | White 5 |
| | | | 226 ⇔ 230 | White 6 |
| | | | 231 ⇔ 235 | White 7 |
| | | | 236 ⇔ 240 | White 8 |
| | | | 241 ⇔ 245 | White 9 |
| | | | 246 ⇔ 251 | White 10 |
| | | | 251 ⇔ 255 | White 11 |
| | 7 | Strobe | 000 ⇔ 009 010 ⇔ 255 | No function 0-20 Hz |
| 8 | Programs | 000 ⇔ 040 | No function | |
| | | 041 ⇔ 050 | Auto 1 | |
| | | 051 ⇔ 060 | Auto 2 | |
| | | 061 ⇔ 070 | Auto 3 | |
| | | 071 ⇔ 080 | Auto 4 | |
| | | 081 ⇔ 090 | Auto 5 | |
| | | 091 ⇔ 100 | Auto 6 | |
| | | 101 ⇔ 110 | Auto 7 | |
| | | 111 ⇔ 120 | Auto 8 | |
| | | 121 ⇔ 130 | Auto 9 | |
| | | 131 ⇔ 140 | Auto 10 | |
| | | 141 ⇔ 150 | Custom 1 | |
| | | 151 ⇔ 160 | Custom 2 | |
| | | 161 ⇔ 170 | Custom 3 | |
| | | 171 ⇔ 180 | Custom 4 | |
| | | 181 ⇔ 190 | Custom 5 | |
| | | 191 ⇔ 200 | Custom 6 | |
| 201 ⇔ 210 | Custom 7 | | | |
| 211 ⇔ 220 | Custom 8 | | | |
| 221 ⇔ 230 | Custom 9 | | | |
| 231 ⇔ 255 | Custom 10 | | | |
| 9 | Auto Speed | 000 ⇔ 255 | 0-100% (only when using Auto 1–10 in CH. 8) | |
| 10 | Dimmer Speed | 000 ⇔ 009 | Preset dimmer speed from display menu | |
| | | 010 ⇔ 029 | Linear dimmer | |
| | | 030 ⇔ 069 | Nonlinear dimming curve 1 (fastest) | |
| | | 070 ⇔ 129 | Nonlinear dimming curve 2 | |
| | | 130 ⇔ 189 | Nonlinear dimming curve 3 | |
| 190 ⇔ 255 | Nonlinear dimming curve 4 (slowest) | | | |
| 11 | Zoom | 000 ⇔ 255 | 0-100% | |
| 12 | Zoom Control | 000 ⇔ 200 | No function | |
| | | 201 ⇔ 220 | Zoom reset | |
| | | 221 ⇔ 255 | No function | |
| AR2.Z | Channel | Function | Value | Percent/Setting |
| | 1 | Dimmer | 000 ⇔ 255 | 0-100% |
| | 2 | Red | 000 ⇔ 255 | 0-100% |
| | 3 | Green | 000 ⇔ 255 | 0-100% |
| | 4 | Blue | 000 ⇔ 255 | 0-100% |
| | 5 | White | 000 ⇔ 255 | 0-100% |
| | 6 | Zoom | 000 ⇔ 255 | 0-100% |
| | 7 | Zoom Control | 000 ⇔ 200 201 ⇔ 220 221 ⇔ 255 | No function Zoom reset No function |

| AR2.S | Channel | Function | Value | Percent/Setting |
|-------|---------|----------|------------------------|------------------------|
| | 1 | Dimmer | 000 ⇔ 255 | 0-100% |
| | 2 | Red | 000 ⇔ 255 | 0-100% |
| | 3 | Green | 000 ⇔ 255 | 0-100% |
| | 4 | Blue | 000 ⇔ 255 | 0-100% |
| | 5 | White | 000 ⇔ 255 | 0-100% |
| | 6 | Strobe | 000 ⇔ 009 010 ⇔ 255 | No function 0-20 Hz |

| AR2.D | Channel | Function | Value | Percent/Setting |
|-------|---------|----------|-----------|-----------------|
| | 1 | Dimmer | 000 ⇔ 255 | 0-100% |
| | 2 | Red | 000 ⇔ 255 | 0-100% |
| | 3 | Green | 000 ⇔ 255 | 0-100% |
| | 4 | Blue | 000 ⇔ 255 | 0-100% |
| | 5 | White | 000 ⇔ 255 | 0-100% |

| ARC.2 | Channel | Function | Value | Percent/Setting |
|-------|---------|----------|-----------|-----------------|
| | 1 | Red | 000 ⇔ 255 | 0-100% |
| | 2 | Green | 000 ⇔ 255 | 0-100% |
| | 3 | Blue | 000 ⇔ 255 | 0-100% |
| | 4 | White | 000 ⇔ 255 | 0-100% |

| AR1.D | Channel | Function | Value | Percent/Setting |
|-------|---------|----------|-----------|-----------------|
| | 1 | Dimmer | 000 ⇔ 255 | 0-100% |
| | 2 | Red | 000 ⇔ 255 | 0-100% |
| | 3 | Green | 000 ⇔ 255 | 0-100% |
| | 4 | Blue | 000 ⇔ 255 | 0-100% |

| ARC.1 | Channel | Function | Value | Percent/Setting |
|-------|---------|----------|-----------|-----------------|
| | 1 | Red | 000 ⇔ 255 | 0-100% |
| | 2 | Green | 000 ⇔ 255 | 0-100% |
| | 3 | Blue | 000 ⇔ 255 | 0-100% |

| HSV | Channel | Function | Value | Percent/Setting |
|-----|---------|------------|-----------|-----------------|
| | 1 | Hue | 000 ⇔ 255 | 0-100% |
| | 2 | Saturation | 000 ⇔ 255 | 0-100% |
| | 3 | Value | 000 ⇔ 255 | 0-100% |

Configuration (Standalone)

Use standalone configuration to operate the product without a DMX controller.

Auto Programs

Auto programs allow for dynamic RGBW color mixing without a DMX controller.

1. Go to the **AUTO** main level
2. Select the desired auto program (**AT. 01–10**) or custom program (**PR. 01–10**)



You cannot edit any of the auto programs (AT. 01–10); however, you can edit the custom programs (PR.01–10). See Edit Custom Programs for details.

Edit Custom Programs

This setting allows the programming of up to 30 scenes for each of the 10 customizable programs, including colors and effects.

1. Go to the **EDIT** main level.
2. Select the desired custom program (**PR. 01–10**).
3. Select the desired scene (**SC. 01–30**).
4. Select the desired color, effect, or timer (**R, G, B, W, S, Z, T, or F**).
5. Select the color, effect, or timer value (**000–255** for colors, effects, and timers or **00–20** for strobe).
6. Repeat for the other colors, effects, or timers.
7. Return to the scene (**SC. 01–30**) level.
8. Repeat the settings of colors, effects, and timers for the other scenes.

Master/Slave

The Master/Slave mode allows a group of Colorado 2 Quad Zoom products (the slaves) to simultaneously duplicate the output of another Colorado 2 Quad Zoom (the master) without a DMX controller.

To set each of the slaves:

1. Go to the **RUN** main level.
2. Select **SLAVE**.

To set the master:

1. Set the running mode to DMX as explained in [DMX Control](#).
2. Select an auto or custom program as explained in [Auto Programs](#), or a static mix of colors..



- The master is the one that runs a program whether in Auto, or Static Color mode.
- Do not connect a DMX controller to the products configured for Master/Slave operation. The DMX controller may interfere with signals from the master.
- The master should be the first product in the daisy chain.

Color Settings

The COLOR setting determines how the Colorado 2 Quad Zoom generates the white color based on various RGB settings.

1. Go to the **SET** main level.
2. Select **COLR**.
3. Select **OFF, RGBW, or UC**.



OFF: When all the RGB faders are set to **255**, the output is maximum, although the resulting white color may not be balanced.

RGBW: When all the RGB faders are set to **255**, the resulting output is defined by the configured white color (see White Calibration).

UC: When all the RGB faders are set to **255**, the output matches that of less efficient products (Universal Color).

Dimmer Profiles

This setting determines how fast the output of the Colorado 2 Quad Zoom changes when you modify the values of the red, green, blue, amber, and dimmer faders. This setting provides four different options to simulate the dimming curve of an incandescent lighting product.

1. Go to the **SET** main level.
2. Select **DIM**.
3. Select a dimmer curve (**OFF**, **DIM1**, **DIM2**, **DIM3**, or **DIM4**).



OFF: The output is proportional (linear) to the dimmer and RGBW channel values.

Dimmer 1-4: The output follows the dimmer and RGBW channel values based on the corresponding dimmer curve, DIM1 being the fastest.

Curve Settings

This setting determines how fast the output of the Colorado 2 Quad Zoom changes when you modify the values of the red, green, blue, amber, and dimmer faders. This setting provides three different options to simulate the dimming curve of an incandescent lighting product.

1. Go to the **SET** main level.
2. Select **CURV**.
3. Select a dimmer curve (**OFF**, **CV1**, **CV2**, or **CV3**).



OFF: The output is proportional (linear) to the dimmer and RGBW channel values.

CV1-3: The output follows the dimmer and RGBW channel values based on the corresponding dimmer curve, **CV1** being the fastest and **CV3** the slowest.



For optimum control of the 16-bit dimming channels in the TR16 and STD.Y personalities, be sure that both dimming curves in SET > DIM and SET > CURV are set to OFF



- When the control panel lock is active, the product will prompt you to enter the passcode after 30 seconds of control panel inactivity or after turning on the product. See [Passcode](#).

Program Upload

This option allows you to copy the custom programs of one Colorado 2 Quad Zoom onto other Colorado 2 Quad Zoom products by using the Master/Slave mode.

1. Configure and connect the products in a Master/Slave arrangement, where the master has the custom programs you want to transfer to the slaves.
2. From the master, go to the **SET** main level.
3. Select **UPLD**
4. When **PASS** shows, press <ENTER>
5. Enter the master access passcode as shown in [Passcode](#).
6. Wait for the upload process to finish (the display will show **END** before continuing or turning the products off.

The master and slaves will provide the status of the process by lighting up as follows:



- **Yellow** indicates that the upload process is running.
- **Green** indicates that the upload process completed successfully.
- **Red** indicates that the upload process failed due to an error. Recheck all cable connections and restart the process. If the issue persists, contact Chauvet Technical Support.



DO NOT upload the data from a Colorado 2 Quad Zoom to a different product. The other product may become inoperative.

Reset

This setting allows you to reset the Colorado 2 Quad Zoom to the default values including the custom programs.

1. Go to the **SET** main level.
2. Select **REST**
3. When **PASS** shows, press <ENTER>.
4. Enter the master access passcode as described in [Passcode](#).
5. Wait for the reset process to finish.

Whites Setting

This setting allows you to select and edit the temperature of the white colors used in channel 6 (Macros) when in the **TOUR** and **C1Q** mode, channel 11 when in the **TR16** and **STD.Y** mode, or channel 19 when in the **FULL** mode.

1. Go to the **CAL** main level.
2. Enter the master access passcode as described in [Passcode](#).
3. Go to **CAL**.
4. Go to **WT**.
5. Select a white color (**WH.01-11**).
6. Select a color (**R**, **G**, **B**, or **W**).
7. Select a color value (**000-255**).
8. Repeat for the other colors.

White Calibration

This setting allows you to select the white color shown by the Colorado 2 Quad Zoom when the color setting is **RGBW** and the DMX controller's red, green, and blue faders are set to 255.

1. Go to the **CAL** main level.
2. Enter the master access passcode as described in [Passcode](#).
3. Go to **RGBW**.
4. Go to **RGB.W**
5. Select a color (**R**, **G**, or **B**).
6. Select a color value (**000-255**).
7. Repeat for the other colors.



- When selecting **CAL > RGBW**, you will only be able to define the values of **R** (red), **G** (green), and **B** (blue).
- The values of **R** (red), **G** (green), and **B** (blue) configured from **CAL > RGBW** will define the color temperature shown when the RGB faders are set to **255** if **SET > COLR > RGBW** is active.

Static Color

The Static Color mode allows for permanent RGBW color mixing without a DMX controller.

1. Go to the **STAT** main level.
2. Select the desired color or effect (**R**, **G**, **B**, **W**, **S**, or **Z**).
3. Select the color or effect value (**000-255** for colors and effect, or **00-20** for strobe).
4. Repeat for the other colors or effects.

6. TECHNICAL INFORMATION

Product Maintenance

To maintain optimum performance and minimize wear, clean this product frequently. Usage and environment are contributing factors in determining the cleaning frequency.

Clean this product at least twice a month. Dust build-up reduces light output performance and can cause overheating. This can lead to reduced light source life and increased mechanical wear.

To clean the product:

1. Unplug the product from power.
2. Wait until the product is at room temperature.
3. Use a vacuum (or dry compressed air) and a soft brush to remove dust collected on the external vents.
4. Clean all transparent surfaces with a mild soap solution, ammonia-free glass cleaner, or isopropyl alcohol.
5. Apply the solution directly to a soft, lint-free cotton cloth or a lens-cleaning tissue.
6. Softly drag any dirt or grime to the outside of the transparent surface.
7. Gently polish the transparent surfaces until they are free of haze and lint.



Always dry the transparent surfaces carefully after cleaning them.

7. TECHNICAL SPECIFICATIONS

Dimensions and Weight

| Length | Width | Height | Weight |
|------------------|------------------|-----------------|------------------|
| 12.9 in (330 mm) | 11.1 in (284 mm) | 9.2 in (236 mm) | 18.8 lb (8.6 kg) |

Note: Dimensions in inches rounded to the nearest decimal digit.

Power

| Power Supply Type | Range | Voltage Selection |
|----------------------|--------------------------|-------------------|
| Switching (internal) | 100 to 240 VAC, 50/60 Hz | Auto-ranging |

| Parameter | 120 V, 60 Hz | 208 V, 60 Hz | 230 V, 50 Hz |
|----------------------------------|---------------------|----------------------|----------------------|
| Consumption | 220 W | 213 W | 228 W |
| Operating current | 1.82 A | 1.03 A | 0.98 A |
| Power-linking current (products) | 13.6 A (7 products) | 13.6 A (12 products) | 13.6 A (13 products) |

| Power I/O | U.S./Worldwide | UK/Europe |
|------------------------|-------------------------|-------------------------|
| Power input connector | Seetronic Powerkon IP65 | Seetronic Powerkon IP65 |
| Power output connector | Edison | Seetronic Powerkon IP65 |
| Power Cord plug | Edison (U.S.) | Local plug |

Light Source

| Type | Power | Lifespan |
|------|-------|--------------|
| LED | 15 W | 50,000 hours |

| Color | Quantity | Current |
|-----------------|----------|---------|
| Quad-color RGBW | 14 | 985 mA |

Photometrics

| Parameter | Narrow Zoom | Wide Zoom |
|-------------------|-------------|-----------|
| Beam angle | 7° | 29° |
| Field angle | 14° | 44° |
| Illuminance @ 5 m | 7,180 lux | 737 |

Thermal

| Maximum External Temperature | Cooling System |
|------------------------------|----------------|
| 113 °F (45 °C) | Convection |

DMX

| I/O Connector | Channel Range |
|------------------|-----------------------------------|
| 3- and 5-pin XLR | 3, 4, 5, 6, 7, 12, or 17 channels |

Ordering

| Product Name | Item Code | UPC Number |
|----------------------|-----------|--------------|
| Colorado 2 Quad Zoom | 01031244 | 781462215927 |



Photometrics Chart

| Distance | Narrow | | Colorado 2 Quad Zoom (Imperial) | | Wide | |
|----------|---------------|----------------|---------------------------------|------------|---------------|----------------|
| | Beam Diameter | Field Diameter | Footcandle | Footcandle | Beam Diameter | Field Diameter |
| 15 ft | 1.83 | 3.68 | 976 | 921 | 2.59 | 4.04 |
| 20 ft | 2.45 | 4.91 | 549 | 58 | 10.34 | 16.16 |
| 30 ft | 3.67 | 7.37 | 244 | 26 | 15.52 | 24.24 |
| 40 ft | 4.89 | 9.82 | 137 | 14 | 20.69 | 32.32 |
| 50 ft | 6.12 | 12.28 | 88 | 9 | 25.86 | 40.40 |
| 75 ft | 9.17 | 18.42 | 39 | 4 | 38.79 | 60.60 |
| 100 ft | 12.23 | 24.56 | 22 | 2 | 51.72 | 80.81 |
| 125 ft | 15.29 | 30.70 | 14 | 1 | 64.65 | 101.01 |
| 150 ft | 18.35 | 36.84 | 10 | 1 | 77.59 | 121.21 |

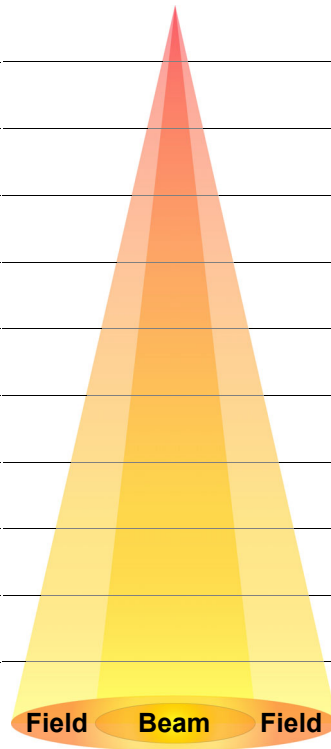

| Distance | Narrow | | Colorado 2 Quad Zoom (Metric) | | Wide | |
|----------|---------------|----------------|-------------------------------|--------|---------------|----------------|
| | Beam Diameter | Field Diameter | Lux | Lux | Beam Diameter | Field Diameter |
| 1 m | 0.12 | 0.25 | 219,500 | 23,025 | 0.52 | 0.81 |
| 2 m | 0.24 | 0.49 | 54,875 | 5,756 | 1.03 | 1.62 |
| 5 m | 0.61 | 1.23 | 8,780 | 921 | 2.59 | 4.04 |
| 8 m | 0.98 | 1.96 | 3,430 | 360 | 4.14 | 6.46 |
| 10 m | 1.22 | 2.46 | 2,195 | 230 | 5.17 | 8.08 |
| 15 m | 1.83 | 3.68 | 976 | 102 | 7.76 | 12.12 |
| 20 m | 2.45 | 4.91 | 549 | 58 | 10.34 | 16.16 |
| 25 m | 3.06 | 6.14 | 351 | 37 | 12.93 | 20.20 |
| 30 m | 3.67 | 7.37 | 244 | 26 | 15.52 | 24.24 |

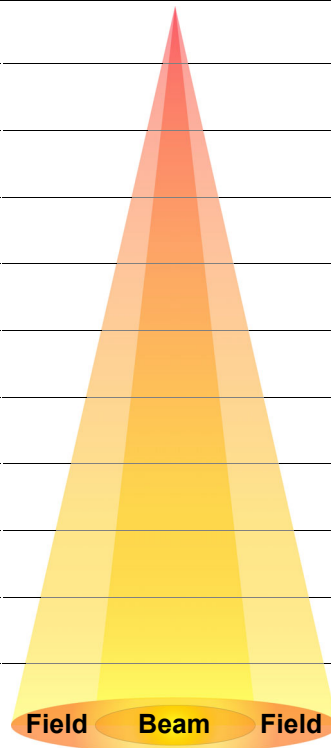

RETURNS

In case you need to get support or return a product:

- If you are located in the U.S., contact Chauvet World Headquarters.
- If you are located in the UK or Ireland, contact Chauvet Europe Ltd.
- If you are located in Benelux, contact Chauvet Europe BVBA.
- If you are located in France, contact Chauvet France.
- If you are located in Germany, contact Chauvet Germany.
- If you are located in Mexico, contact Chauvet Mexico.
- If you are located in any other country, DO NOT contact Chauvet. Instead, contact your local distributor. See www.chauvetprofessional.com for distributors outside the U.S., UK, Ireland, Benelux, France, Germany, or Mexico.



If you are located outside the U.S., UK, Ireland, Benelux, France, Germany, or Mexico, contact your distributor of record and follow their instructions on how to return Chauvet products to them. Visit our website www.chauvetprofessional.com for contact details.

Call the corresponding Chauvet Technical Support office and request a Return Merchandise Authorization (RMA) number before shipping the product. Be prepared to provide the model number, serial number, and a brief description of the cause for the return.

To submit a service request online, go to www.chauvetprofessional.com/service-request.

Send the merchandise prepaid, in its original box, and with its original packing and accessories. Chauvet will not issue call tags.

Clearly label the package with the RMA number. Chauvet will refuse any product returned without an RMA number.



Write the RMA number on a properly affixed label. DO NOT write the RMA number directly on the box.

Before sending the product, clearly write the following information on a piece of paper and place it inside the box:

- Your name
- Your address
- Your phone number
- RMA number
- A brief description of the problem

Be sure to pack the product properly. Any shipping damage resulting from inadequate packaging will be your responsibility. FedEx packing or double-boxing are recommended.



Chauvet reserves the right to use its own discretion to repair or replace returned product(s).

CONTACT US

| General Information | Technical Support |
|--|--|
| Chauvet World Headquarters | |
| Address: 5200 NW 108th Ave. Sunrise, FL 33351 Voice: (954) 577-4455 Fax: (954) 929-5560 Toll Free: (800) 762-1084 | Voice: (844) 393-7575 Fax: (954) 756-8015 Email: chauvetcs@chauvetlighting.com Website: www.chauvetdj.com |
| Chauvet Europe Ltd | |
| Address: Unit 1C Brookhill Road Industrial Estate Pinxton, Nottingham, UK NG16 6NT Voice: +44 (0) 1773 511115 Fax: +44 (0) 1773 511110 | Email: UKtech@chauvetlighting.eu Website: www.chauvetdj.eu |
| Chauvet Europe BVBA | |
| Address: Stokstraat 18 9770 Kruishoutem Belgium Voice: +32 9 388 93 97 | Email: BNLtech@chauvetlighting.eu Website: www.chauvetdj.eu |
| Chauvet France | |
| Address: 3, Rue Ampère 91380 Chilly-Mazarin France Voice: +33 1 78 85 33 59 | Email: FRtech@chauvetlighting.fr Website: www.chauvetdj.eu |
| Chauvet Germany | |
| Address: Bruno-Bürgerl-Str. 11 28759 Bremen Germany Voice: +49 421 62 60 20 | Email: DEtech@chauvetlighting.de Website: www.chauvetdj.eu |
| Chauvet Mexico | |
| Address: Av. de las Partidas 34 - 3B (Entrance by Calle 2) Zona Industrial Lerma Lerma, Edo. de México, CP 52000 Voice: +52 (728) 690-2010 | Email: servicio@chauvet.com.mx Website: www.chauvetdj.mx |

Outside the U.S., U.K., Ireland, Benelux, France, Germany, or Mexico, contact the dealer of record. Follow the instructions to request support or to return a product. Visit our website for contact details.